



4 **FEDORA**
DIMA LOGINOFF
12 TECHNICAL DATA
14 INTERVIEW



FA FEDORA **LED**



SP FEDOR 1 **LED**



SP FEDOR 3 **LED**

16 **MELTING POT**
SANDRO SANTANTONIO
26 TECHNICAL DATA



AP MELTIN **+ LED**



SP MELT 60 **+ LED**

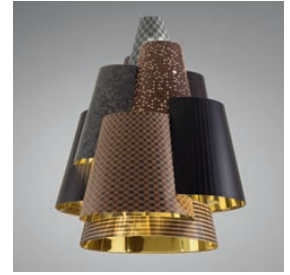

SP MEL 120 **+ LED**

28 **HOOPS**
GIOVANNI BARBATO
36 TECHNICAL DATA



PL HOOPS 2 **LED**



PL HOOPS 3 **LED**

38 **NAFIR** (2 NEW FINISHINGS)
KARIM RASHID
46 TECHNICAL DATA

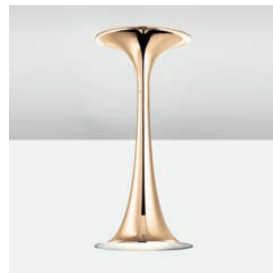

PL NAFIR 1 **LED**

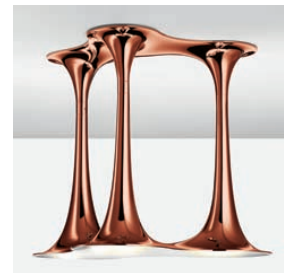

PL NAFIR 3 **LED**

48 **SPILLRAY** (NEW FINISHING)
MANUEL VIVIAN
54 TECHNICAL DATA



SP SPILL P / M / G

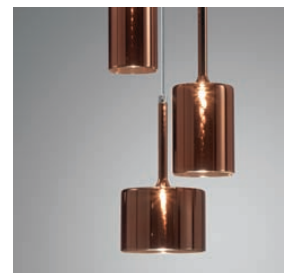

SP SPILL 3

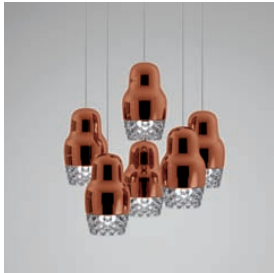

SP FEDOR 6 **LED**



SP FEDOR 7 **LED**



SP FEDO 12 **LED**



DIMMA LOGINOFF INTERVIEW



SP MEL 115 **+ LED**

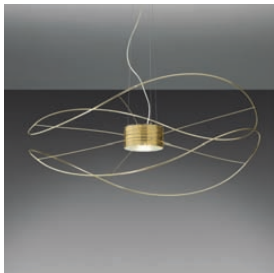

SP HOOPS 2 **LED**



SP HOOPS 3 **LED**



SP HOOPS 4 **LED**



SP HOOPS 6 **LED**



SP NAFIR 1 **LED**



SP NAFIR 3 **LED**



SP SPILL 6



SP SPIL 10

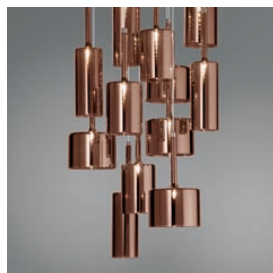

SP SPIL 12

LED Prodotto disponibile solo con tecnologia LED / Product only available with LED technology

+ LED Prodotto disponibile con LED o lampadine convenzionali / Product only available with LED or conventional lamp technology

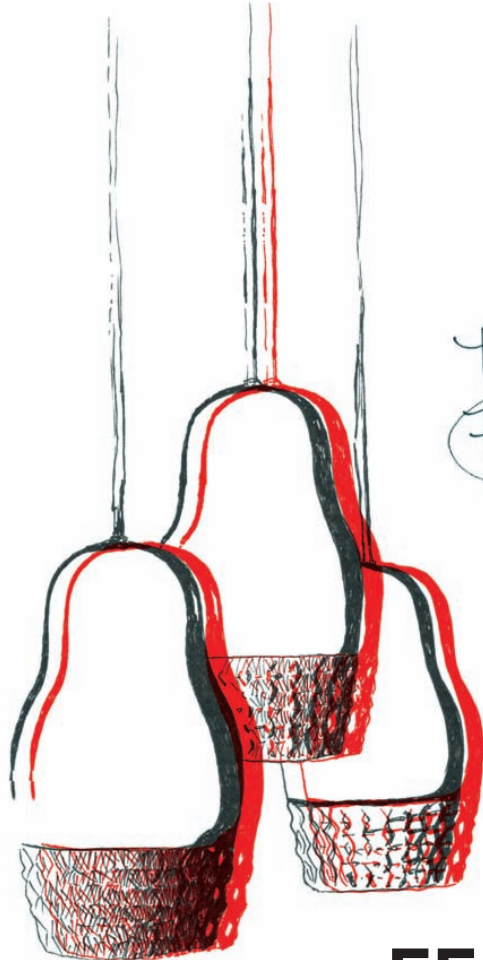

Three Sisters
FEDORA
 Dima Loginoff

FEDORA DIMA LOGINOFF

Collezione composta da sospensioni e faretto ad incasso. Il diffusore delle sospensioni (a una, tre, sei e dodici luci, oltre ad una versione a sette luci in linea) è formato da una parte in alluminio disponibile nei colori bronzo metallizzato e oro rosa e da una parte in vetro trasparente. Il faretto ad incasso è costituito dalla sola parte in vetro trasparente. Fonte luminosa LED con attacco GU10.

A collection comprising hanging lamps and a built-in spotlight. The diffuser of the hanging lamps (with one, three, six or twelve lights, or with seven lights in a line) is formed of a part in aluminium available in metallic bronze and rose gold, and another part in transparent glass. The built-in spotlight is formed of one part in transparent glass. LED light source with GU10 fitting.

Kollektion von Hängelampen und Einbaustrahler. Ein Teil des Schirms der Hängelampen (mit einem, drei, sechs und zwölf Leuchtkörpern, sowie eine lineare Version mit sieben Leuchtkörpern) besteht aus metallic-bronze oder rotgold-farbigem Aluminium und der andere aus klarem Glas. Der Einbaustrahler besteht nur aus dem Teil aus durchsichtigem Glas. Lichtquelle: LED mit GU10-Anschluss.

Collection composée de suspensions et spot encastré. Le diffuseur des suspensions (à une, trois, six et douze lumières, ainsi qu'une version à sept lumières à rampe) est formé d'une partie en aluminium disponible dans les couleurs bronze métallisé et doré rose et d'une partie en verre transparent. Le spot encastré est constitué seulement d'une partie en verre transparent. Source de lumière à LED avec bord d'attaque GU10.

Colección compuesta por suspensiones y foco empotrable. El difusor de las suspensiones (de una, tres, seis y doce luces, además de una versión de siete luces en línea) está formado por una parte de aluminio, disponible en los colores bronce metalizado y oro rosa, y por una parte en cristal transparente. El foco empotrable está formado solo por cristal transparente. Fuente luminosa LED con casquillo GU10.

Coleção composta por pendentes e spots de embutir. O difusor dos pendentes (com uma, três, seis e doze luzes, além de uma versão com sete luzes alinhadas) é formado por uma parte de alumínio, disponível nas cores bronze metalizado e ouro rosa, e de uma parte de vidro transparente. O spot de embutir é constituído por apenas uma parte de vidro transparente. Fonte luminosa LED com encaixe GU10.

Коллекция состоит из подвесных и встраиваемых светильников. Подвесные светильники (одиночные, тройные, а также модели с шестью, двенадцатью и дополнительной линейкой из семи ламп) имеют две части: верхняя часть изготовлена из алюминия и покрыта металлизированным опылением (цвета: бронзовый металл и розово-золотой), а вторая часть выполнена из прозрачного стекла. Встраиваемые светильники изготовлены из прозрачного стекла. Источник света: светодиодные лампы с цоколем GU10.







< SP FEDOR 7
« PG 4-5: SP FEDOR 3



^ SP FEDO 12
> SP FEDO 12







^ SP FEDOR 6
< FA FEDORA

TECHNICAL DATA

FINITURE / FINISHINGS



oro rosa / rose gold



bronzo metallizzato / metallic bronze





FA FEDORA

base / bulb type GU10 **LED** bulbs
power 1 x Max 7.5 W
ilcos DRPAR LED 
marks  

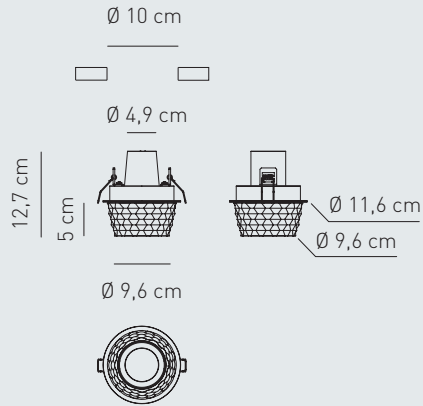
hole \varnothing 10 cm / min depth 10 cm



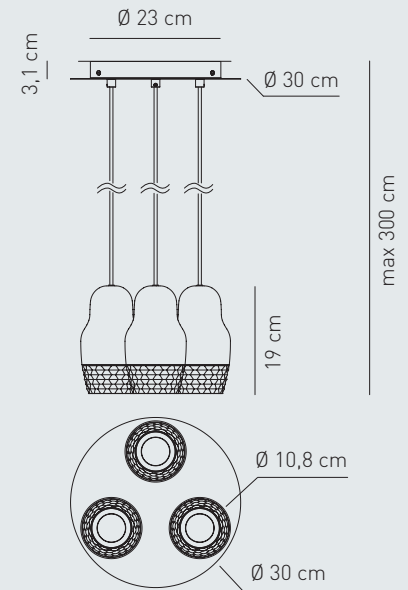

SP FEDOR 3

base / bulb type GU10 **LED** bulbs
power 3 x Max 7.5 W
ilcos DRPAR LED 
marks  



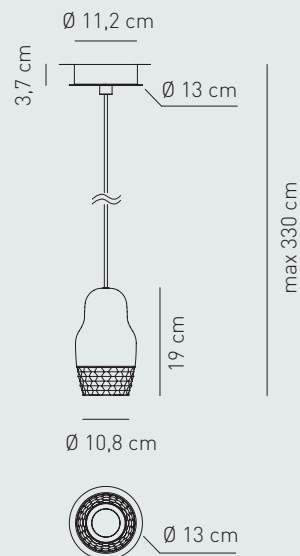

SP FEDOR 1

base / bulb type GU10 **LED** bulbs
power 1 x Max 7.5 W
ilcos DRPAR LED 
marks  



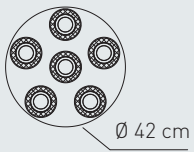
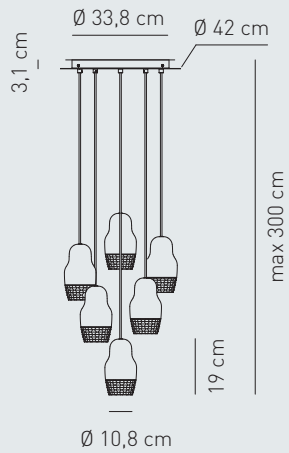

SP FEDOR 6

base / bulb type GU10 **LED** bulbs
power 6 x Max 7.5 W
ilcos DRPAR LED 
marks   IP20



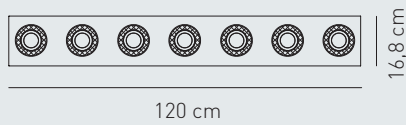
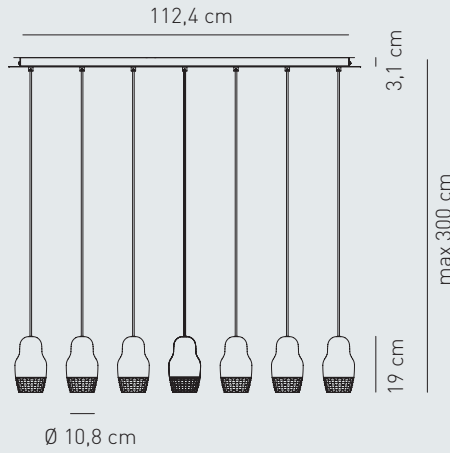

SP FEDOR 7

base / bulb type GU10 **LED** bulbs
power 7 x Max 7.5 W
ilcos DRPAR LED 
marks   IP20



SP FEDO 12

base / bulb type GU10 **LED** bulbs
power 12 x Max 7.5 W
ilcos DRPAR LED 
marks   IP20

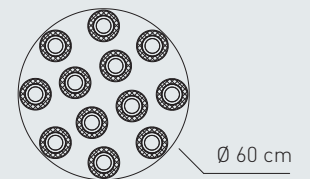
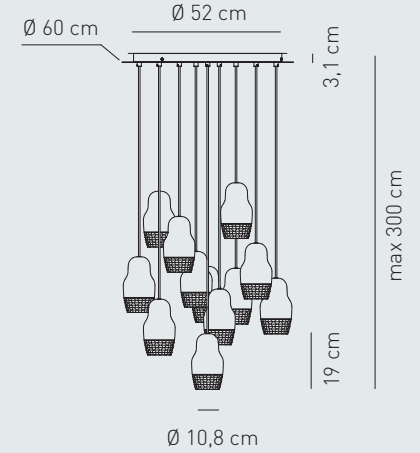



INTERVISTA DI LORENZO TRUANT, ART DIRECTOR DI AXO LIGHT A DIMA LOGINOFF

Cosa significa per te Fedora, ed il suo riferimento formale alla bambola tradizionale russa che noi conosciamo col nome di matrioska e che tutto il mondo riconosce come tipica del tuo paese?

Si tratta di tradizione russa, ma ha una forma molto minimale se confrontata con altre icone della tradizione russa. Inoltre, a differenza di quello che la maggior parte delle persone pensa della Matrioska, non è così vecchia. Ha la stessa età del cinematografo e l'idea di vari strati che ti portano poi a trovare una bambola all'interno viene dal Giappone. Ma non preoccuparti... Tantissimi russi pensano che la Matrioska abbia almeno 500 o 1000 anni; divertente, no? Ho parecchie bambole a casa. Ne ho una semplice e dipinta di un solo colore: oro. Nonostante io sia definito "il designer meno russo in Russia", amo questa forma e pare che sia proprio nel mio DNA. Il nome Fedora è un vecchio e dimenticato nome russo il cui diminutivo è Dora. Lo adoro! Era il nome della mia bisnonna!

Che rapporto hai con la tradizione, e con le forme del passato? Non intendo solo la tradizione Russa, in generale mi riferisco alle storie delle forme che spesso influenzano più o meno artisti e designers.

Ho un rapporto abbastanza stretto con la tradizione. Sono un grande fan del minimalismo ma allo stesso tempo la mia mente è sempre in contrasto a causa di influenze storiche. E non mi riferisco solo allo stile storico russo. FRAME in un suo libro dove si parlava anche del mio design ha scritto: "...forme sensuali...con una sensazione generale di nuovo lusso e di passato che incontra il presente". Pare io mi stia divertendo con questo bellissimo gioco nel design in cui cerco di sposare il moderno alla tradizione.

Negli oggetti che disegni esiste, a mio parere, un legame nascosto col passato che viene trasfigurato dalla naturale consapevolezza della tua capacità compositiva che è tutta contemporanea. Questo elemento nascosto è letteralmente fuso nelle tue realizzazioni che sono perciò spesso familiari e accattivanti, assolutamente nuove ma con un legame segreto con la storia delle forme, come se il risultato scaturisse da una alchimia tra il contemporaneo e una "archeologia sognata", un personale distillato della storia, che si condensa in una idea però sempre nuova. Quale è veramente il tuo processo progettuale, il tuo habitus operativo quando lavori attorno ad una idea, ad un prodotto, e in particolare ad una lampada?

Non è strano che oggi in questo progetto io abbia deciso di unire il vecchio al moderno. In generale dipende dalla forma. Lo sai, ho disegnato tanti oggetti ultramoderni ma a volte semplicemente sento che le forme classiche siano perfette da ridisegnare per farle diventare un prodotto moderno. A volte semplicemente sento che funziona.

Spesso in Europa, il gusto Russo e di buona parte dell'est Europa viene identificato come un gusto molto sofisticato, esigente, legato a stilemi storici, opulenti, qualche volta legato a rappresentare degli status sociali piuttosto che a reali esigenze funzionali e di aderenza alla contemporaneità. Pensi che sia corretta questa visione? Quanto la cultura locale e nazionale prevalente ti ha influenzato e quanto invece incide la globalizzazione dei valori nel tuo lavoro di designer? Cosa ne pensi dell'approccio "glocal" nel campo del design? Quando disegni un prodotto ti senti obbligato a rispettare un gusto prevalente per assecondare un mercato o segui liberamente il tuo istinto ed il tuo stile?

Molte persone mi hanno chiesto del "gusto russo" ma davvero non ho saputo aiutarli. Non ho la minima idea di cosa succeda in questo campo. Probabilmente è per questo che non ho ancora disegnato per nessuna Azienda russa. Certamente ci sono differenze con il resto del mondo. Nuovo denaro, nuovo potere, nuove modalità di espressione... i ricchi spesso sembrano strani ma quello che ho notato è che imparano velocemente e stanno cambiando. Puoi facilmente trovare residenze assolutamente moderne, semplici e lussuose così come abitazioni moderne in periferia per la classe media. E fortunatamente quello che ho riscontrato non ha una connotazione particolarmente "tradizionale". Per quanto mi riguarda inizio la giornata con una tazza di caffè e i blog di design. Guardo molto tutto quello che riguarda il design e non perché devo ma perché questa è la mia passione, è parte della mia vita. Il mercato locale non mi influenza, il mondo del design sì.

Come non mai per la cultura Russa la luce è un elemento metafisico, e la pittura di icone che ci svela Pavel Florenskij ne è la prova più consistente. In questa prospettiva culturale, progettare la luce comporta qualche riflessione in più? Hai una particolare predisposizione al progetto di lampade o per te è indifferente disegnare una sedia, un tavolo, piuttosto che una lampada?

Disegnare lampade è uno degli aspetti del mio lavoro che preferisco. L'idea include così tante sfaccettature...: forma ed estetica, la luce, i raggi luminosi, le ombre. E tutti si dimenticano dell'oscurità; con un gesto illumini l'oscurità. Quale altro prodotto di design può farlo? Ovviamente però non disegno solo lampade. Per esempio, attualmente sto lavorando su un sistema acustico innovativo.

Facciamo un gioco! Io elenco una coppia di parole, non necessariamente opposte o perfettamente dialoganti fra loro, e tu, se vuoi, fai un breve commento, o mi racconti un aneddoto, o fai una riflessione. Il gioco serve per permetterci di capire il valore delle parole e cosa innescano in noi, a seconda della cultura di appartenenza e delle esperienze che abbiamo avuto. Usa se vuoi anche l'ironia:

Funzione / Ragione

Non stanno sempre al primo posto per quanto mi riguarda.

Tradizione / Innovazione

Potrebbero essere mixate per ottenere un buon design.

Passato / Futuro

Nelle nostre vite è una linea ma in una fase di meditazione (e quindi magari di creatività) puoi giocarci.

Arte / Design

Fratelli. E design è il più giovane dei due.

Artigianato / Industria

Nemici.

Luce / Buio

L'energia. E la lampada è uno strumento per giocare con l'oscurità (lo so... è troppo spirituale!!).

Fisica / Metafisica

Due modi per conoscere l'energia.

Occidentale / Orientale

Due tipi di consapevolezza, individuale e collettiva.

Corpo / Spirito

Sono la stessa cosa di Fisica e Metafisica.

Bello / Brutto

Il concetto più incostante.

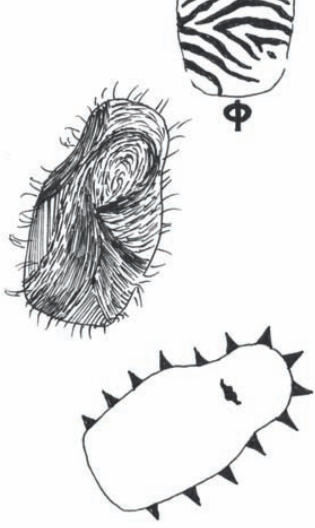

**INTERVIEW BY LORENZO TRUANT,
AXO LIGHT ART DIRECTOR
TO DIMA LOGINOFF**

What does Fedora mean to you? And what about its formal reference to the traditional Russian doll we know as matryoshka and which the whole world typically associates to your country?

It's traditional Russian, but it has the most minimal shape comparing with other Russian icons. Besides, despite what many people are thinking about Matryoshka - it's not too old. In fact it's the same age as cinematograph. And the idea of many layers when you may find one doll inside another came from Japan. But don't worry! Many Russians are thinking that Matryoshka is 500 or 1000 years old. That's funny! I have several dolls at my home. It's simple and painted just in one bold color - gold. Despite people called me "the less Russian designer in Russia", I love this shape and it seems it's in my DNA. The name Fedora is the old and forgotten Russian name. And the short name is Dora. I just love it! That was the name of my great-grandmother.

How close are you to tradition and to shapes from the past? In other words, not only Russian tradition but I mean the history of shapes which often somehow influence artists and designers.

Quite close. I am a big fan of minimalism. But same time I always have this contrast in my mind - historical influence. And I mean not only Russian historical styles. FRAME wrote about my design in their book "...sensuous forms... with an overall feeling of nouveau luxury and past meets present". It seems I am playing a wonderful game in design when I am trying to marriage modern and traditional.

*Playing with
matryoshka
FEDORA
Dima Loginoff*

I think the objects you design have a hidden connection with the past which is transfigured by your natural awareness of your contemporary creative talent. This hidden element is literally melted in your works which are therefore often familiar and appealing, brand-new but with a secret connection with the history of shapes; it looks as if the result arose from an alchemy between contemporary art and a "dream archaeology", a personal essence of history which every time turns into a new idea. How do you actually work on a project, I mean what are you used to doing when you work around an idea, a product and in particular a lamp?

It's not like you decide to connect modern and old in a new project. It depends on the shape in general. You know I have many ultramodern things, but sometimes I just feel that this classical shape will be great to redesign and turn into the modern product. Sometimes I just feel that it works.

In Europe the Russian as well as the Eastern European taste is often identified with a very sophisticated, demanding, historic, classy and fancy style meant to enhance a social status rather than to meet an actual contemporary need. Do you agree with this view? How much has the predominant local and national culture influenced you? How much has the globalization of values "shaped" your job as a designer? What do you think about the "glocal" approach in the design industry? When you design a product, do you feel you have to follow a main taste to go along with a market or do you freely follow your instinct as well as your style?

Many people asked me about «Russian taste». But I can't help them. I just don't know what's going on in that field. Maybe that's why I haven't designed for any Russian company yet. Of course, there is the different with other world. The new money, new power, new ways of expression. Rich people often looks strange, but what I noticed - they learned fast and they are changing. You can easily find absolutely modern, simple and expensive residences as well as modern townhouses in suburbs for middle class. And what I saw doesn't looks like too «traditional» luckily. As for me I start my day with a cup of espresso and design blogs. I am checking a lot of design content, but not because I have to. That's my passion, that's a part of my life. Local market doesn't influenced on me at all, the world design does.



Now, more than ever, light is a metaphysical element for the Russian culture and the icon paintings revealed by Pavel Florenskij are the most significant pieces of evidence. In this cultural perspective, is there more reflection when it comes to designing light? Are you particularly keen on designing lamps or do you indifferently design a chair, a table rather than a lamp?

Designing lamps is one of my favorite part of my work. It has so many layers inside of the idea. Shape and esthetic, the light, the light rays, the shadows. And people always forget about the darkness. In one turn you light up the darkness. Which other piece of design can do that? But of course I design not just the lightings. For example now I am working on innovative hi-end acoustic systems.

Let's play a game: I'll list several pairs of words, not necessarily opposites or perfectly linked between each other and if you want to you can make a brief comment, tell me an anecdote or what you think about them. This game is meant to understand the value of words and what they can trigger inside a person according to the culture he or she comes from and what he or she has experienced:

Function / Reason

not always on the first place for me.

Tradition / Innovation

could be mixed with a good design.

Past / Future

In our lives it's the line. But during the meditation (as designing) you can play with that.

Art / Design

Brothers. And design is the youngest one.

Handicraft / Industry

Enemies.

Light / Darkness

The Energy. And the lamp is a tool to play with that. (I know it's too spiritually).

Physics / Metaphysics

Two ways of knowing the Energy.

Western / Eastern

Two type of conscience. Individual and Collective.

Body / Spirit

Same as Physics / Metaphysics absolutely.

Beautiful / Ugly

The most inconstant concept .

MELTING POT SANDRO SANTANTONIO

Collezione composta da sospensioni e applique.

Le sospensioni sono di tre dimensioni: Ø102 cm a tre luci, Ø51 cm a una luce e versione lineare 120 cm a quattro luci. L'applique è offerta in un'unica misura a due luci. I paralumi sono proposti con diversi pattern decorativi disponibili in una versione chiara con interno bianco e in una versione scura con interno oro. Diffusori opalescenti disponibili su richiesta. Fonte luminosa con attacco E27 per le sospensioni e per l'applique.

A collection comprising hanging lamps and a wall lamp.

The hanging lamps are available in three sizes: Ø102 cm with three lights, Ø51 cm with one light, and a 120 cm linear version with four lights. The wall lamp is available in one size with two lights. The lampshades come in various decorative patterns and in either a light version that is white on the inside or in a dark version that is gold on the inside. Opalescent diffusers available on request. Light source with E27 fitting for hanging lamps and for the wall lamp.

Kollektion von Hängelampen und Wandleuchten. Die Hängelampen sind in drei verschiedenen Größen erhältlich: Ø102 cm mit drei Leuchtkörpern, Ø51 cm mit einem Leuchtkörper und die lineare Ausführung mit 120 cm und vier Leuchtkörpern. Die Wandleuchte wird in einer Größe und mit zwei Leuchtkörpern angeboten. Die Leuchtschirme sind mit verschiedenen Gestaltungsmustern und in einer hellen Ausführung, deren Inneres weiß ist, und einer dunklen Ausführung, deren Inneres goldfarben ist, erhältlich. Opalisierende Lampenschirme auf Anfrage erhältlich. Lichtquelle mit E27-Anschluss für die Hängelampen und für die Wandleuchte.

Collection composée de suspensions et appliques.

Les suspensions sont en trois dimensions. Ø102 cm à trois lumières, Ø51 cm à une lumière et version linéaire 120 cm à quatre lumières. L'applique est proposée en une seule mesure à deux lumières. Les abat-jour sont proposés en différentes solutions décoratives disponibles dans la version claire, intérieur blanc, et une version foncée, intérieur doré. Diffuseurs opalescents disponibles sur demande. Source lumineuse avec bord d'attaque E27 pour les suspensions et pour l'applique.

Colección compuesta por suspensiones y apliques. Las suspensiones son de tres dimensiones: Ø102 cm de tres luces, Ø51 cm de una luz y versión lineal 120 cm de cuatro luces. El aplique se presenta en una sola medida con dos luces. Las pantallas se proponen con diferentes modelos decorativos disponibles en una versión clara con interior blanco y en una versión oscura con interior oro. Difusores opalescentes disponibles a petición. Fuente luminosa con casquillo E27 para las suspensiones y para el aplique.

Coleção composta por pendentes e arandelas. Os pendentes são de três dimensões: Ø102 cm com três luzes, Ø51 cm com uma luz e versão linear 120 cm com quatro luzes. A arandela é oferecida em uma medida única com duas luzes. As cúpulas são propostas com diversos padrões decorativos disponíveis em uma versão clara com interior branco e uma versão escura com interior ouro. Difusores opalescentes disponíveis mediante solicitação. Fonte luminosa com encaixe E27 para os pendentes e para a arandela.

Коллекция состоит из подвесных и настенных светильников. Подвесные светильники представлены в трёх вариациях: длиной 102 см с тремя плафонами, подвес 51 см с одним плафоном и линейный вариант 120 см с четырьмя плафонами. Настенные светильники представлены в одном варианте: с двумя плафонами. Плафоны светильников украшены декоративными узорами и представлены различными цветовыми вариациями: светлый принт снаружи – белый фон внутри, тёмный принт снаружи – золотой фон внутри. Диффузоры Opalescent (или Опаловые диффузоры) могут быть предоставлены по запросу. Источник света: лампы с цоколем E27 для подвесных светильников и для настенных.



Sandro Santantonio



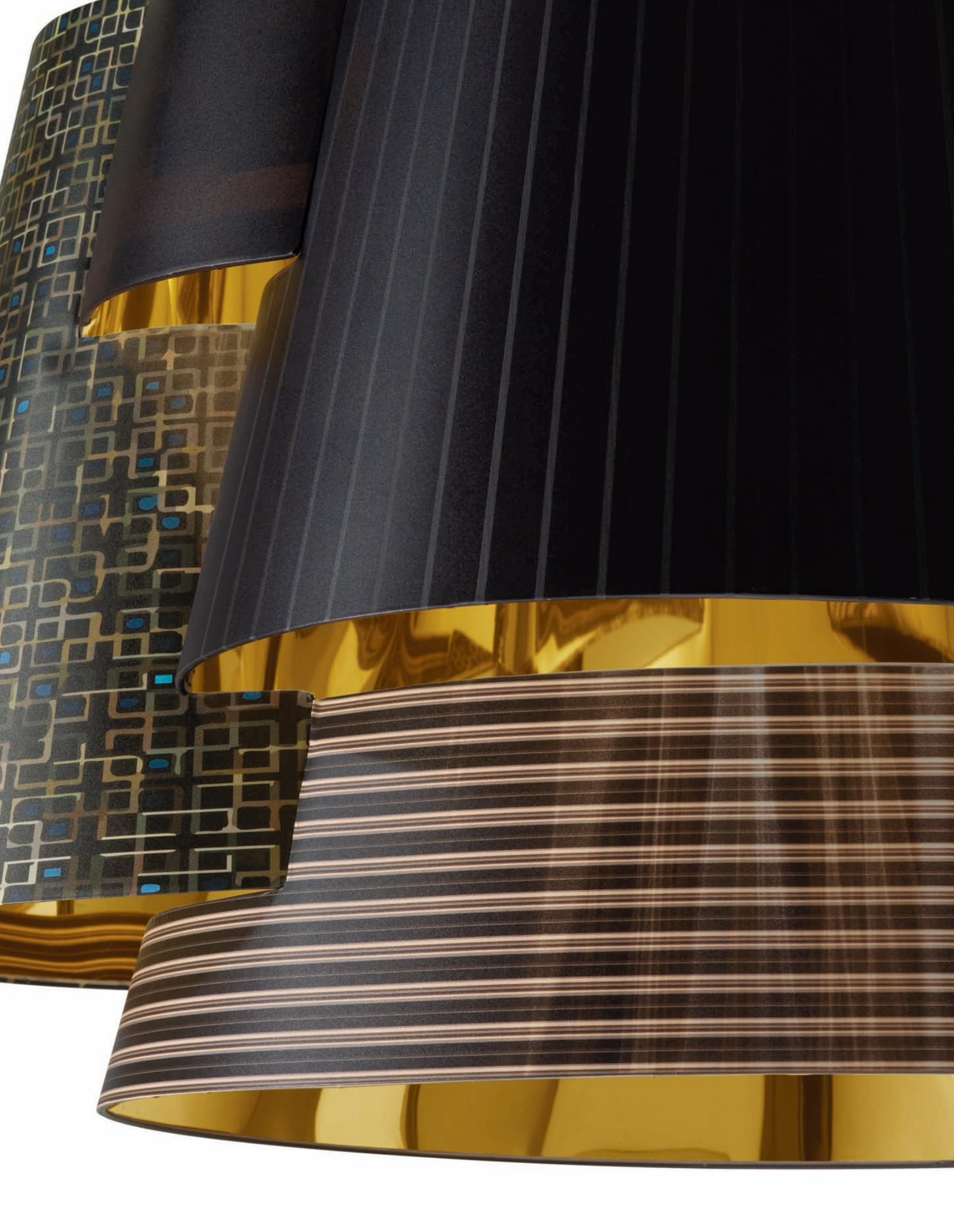





^ SP MEL 120 WITH A DIFFUSER (OPTIONAL)
< SP MEL 120
« PG 16-17: SP MEL 120



^ AP MELTIN
> SP MELT 60 / AP MELTIN







^ AP MELTIN
< SP MELT 60 WITH 2 DIFFUSERS (OPTIONAL)



^ SP MEL 115
> SP MEL 115



TECHNICAL DATA

FINITURE / FINISHINGS

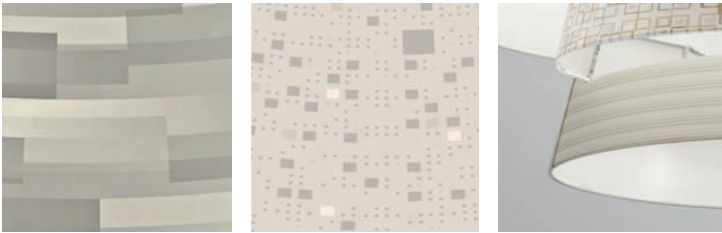
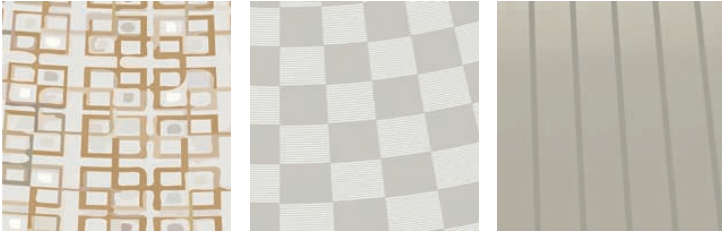

fantasie chiare – interno bianco / light patterns – white inside



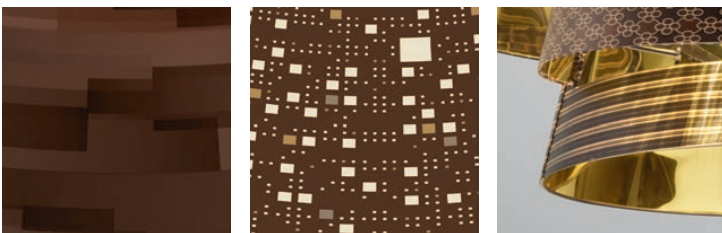
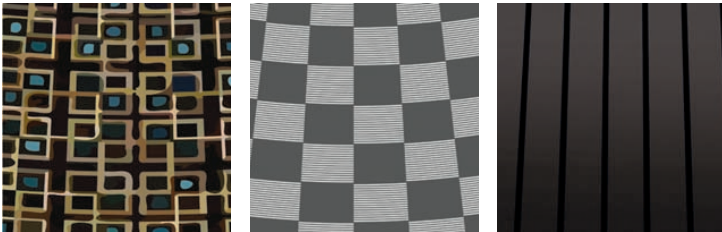



fantasie scure – interno oro / dark patterns – gold inside





AP MELTIN

base / bulb type E27 LED bulbs
power 2 x Max 16 W
ilcos DRAA 
marks CE  IP20

base / bulb type E27 fluorescent
power 2 x Max 15 W
ilcos FB 
marks CE  IP20

base / bulb type E27 halogen
power 2 x Max 30 W
ilcos HSGSA 
marks CE  IP20

base / bulb type E27 incandescent*
power 2 x Max 40 W
ilcos IAA 
marks CE  IP20

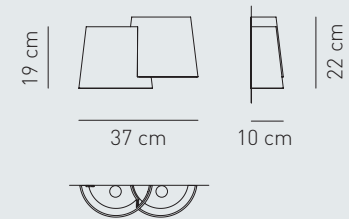





*Nei paesi non AEE il prodotto con attacco E27 è compatibile con lampade ad incandescenza ILCOS IAA.



*In countries outside the EEA the product with E27 is compatible with incandescent ILCOS IAA.





SP MELT 60

base / bulb type E27 LED bulbs
 power 1 x Max 16 W
 ilcos DRAA 
 marks CE  IP20

base / bulb type E27 fluorescent
 power 1 x Max 23 W
 ilcos FB 
 marks CE  IP20



base / bulb type E27 halogen
 power 1 x Max 70 W
 ilcos HSGSA 
 marks CE  IP20

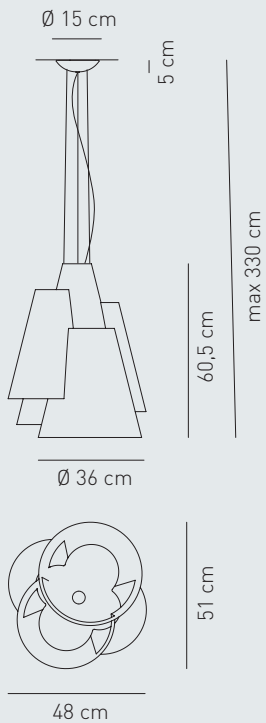

base / bulb type E27 incandescent*
 power 1 x Max 100 W
 ilcos IAA 
 marks CE  IP20



available with 2 diffusers (optional)





SP MEL 120

base / bulb type E27 LED bulbs
 power 3 x Max 16 W
 ilcos DRAA 
 marks CE  IP20

base / bulb type E27 fluorescent
 power 3 x Max 23 W
 ilcos FB 
 marks CE  IP20



base / bulb type E27 halogen
 power 3 x Max 70 W
 ilcos HSGSA 
 marks CE  IP20

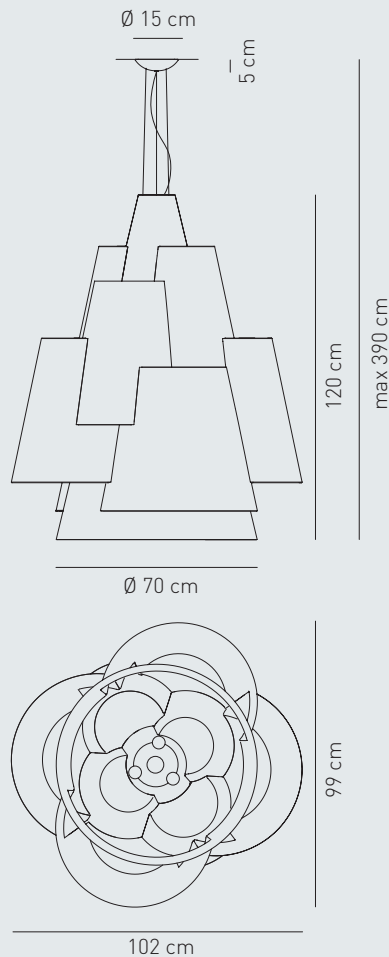

base / bulb type E27 incandescent*
 power 3 x Max 100 W
 ilcos IAA 
 marks CE  IP20



available with a diffusers (optional)





SP MEL 115

base / bulb type E27 LED bulbs
 power 4 x Max 16 W
 ilcos DRAA 
 marks CE  IP20

base / bulb type E27 fluorescent
 power 4 x Max 23 W
 ilcos FB 
 marks CE  IP20

base / bulb type E27 halogen
 power 4 x Max 70 W
 ilcos HSGSA 
 marks CE  IP20

base / bulb type E27 incandescent*
 power 4 x Max 100 W
 ilcos IAA 
 marks CE  IP20

available with 4 diffusers (optional)

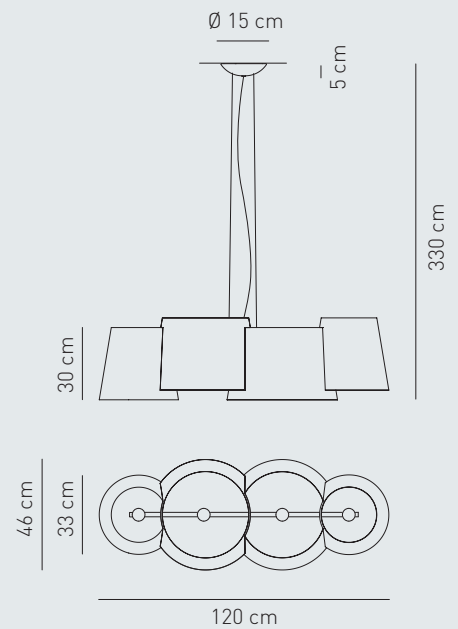

with diffusers

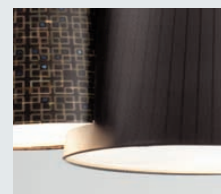

without diffusers

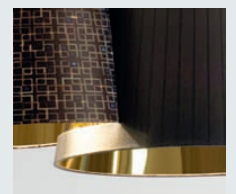

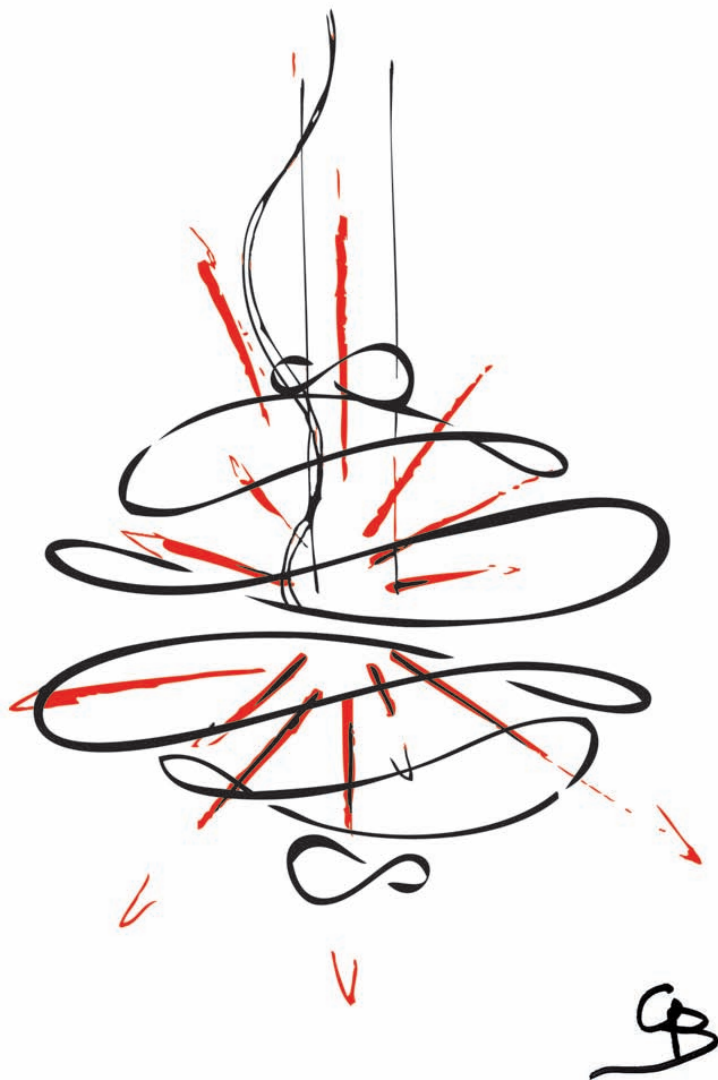

HOOPS GIOVANNI BARBATO

Collezione composta da sospensioni e plafoniere con elementi intercambiabili di tre diverse forme e dimensioni. Finitura dorata con oro 24K. Fonte luminosa: LED integrato. La sospensione prevede un'illuminazione uplight e downlight, in contemporanea.

A collection comprising hanging lamps and ceiling lamps with interchangeable elements in three different shapes and sizes. 24K gold finish. Light source: integrated LED. The hanging lamp can light upward and downward at the same time.

Kollektion von Hängelampen und Deckenleuchte mit austauschbaren Elementen in drei verschiedenen Formen und Größen. Veredelt mit 24 K Gold. Lichtquelle: Eingebautes LED. Die Hängelampe sieht eine gleichzeitige Beleuchtung nach oben und unten vor.

Collection composée de suspensions et plafonniers avec des éléments interchangeables de trois formes et dimensions différentes. Finition dorée feuille d'or 24 carats. Source lumineuse: LED intégré. La suspension a une illumination uplight et downlight simultanée.

Colección compuesta por suspensiones y plafones con elementos intercambiables de tres formas y tamaños diferentes. Acabado dorado con oro 24K. Fuente luminosa: LED integrado. La suspensión prevé una iluminación uplight y downlight, contemporáneamente.

Coleção composta por pendentes e plafons com elementos intercambiáveis com três formas e dimensões diferentes. Acabamento dourado com ouro 24K. Fonte luminosa: LED integrado. O pendente prevê uma iluminação uplight e downlight, de modo simultâneo.

Коллекция состоит из потолочных и подвесных светильников, покрытых золотым опылением (золото 24 карата), со сменными элементами трех разных форм и размеров. Источник света: встроенный светодиод. Подвесные светильники обеспечивают одновременное разнонаправленное освещение вверх и вниз.







^ PL HOOPS 2
< PL HOOPS 3
« PG 28-29 : PL HOOPS 3



^ SP HOOPS 4
> SP HOOPS 6



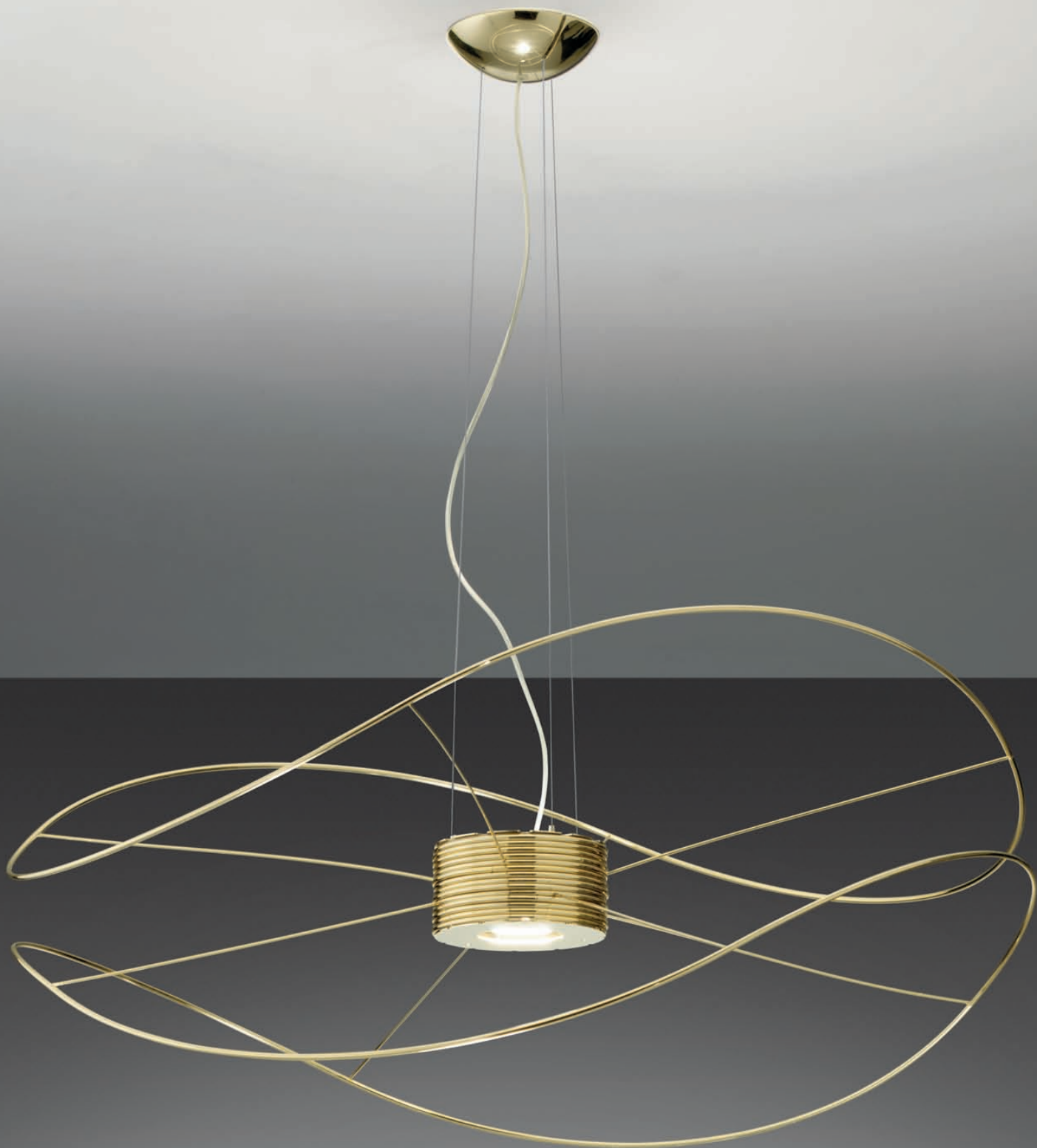



^ SP HOOPS 3
< SP HOOPS 2

TECHNICAL DATA

PL HOOPS 2

source integrated **LED** warm light
power 1 x 17.5 W
output / efficiency 1230lm - 70lm/W
marks **CE**  IP20

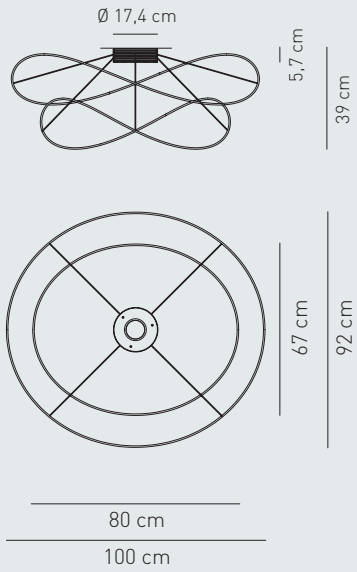

PL HOOPS 3

source integrated **LED** warm light
power 1 x 17.5 W
output / efficiency 1230lm - 70lm/W
marks **CE**  IP20

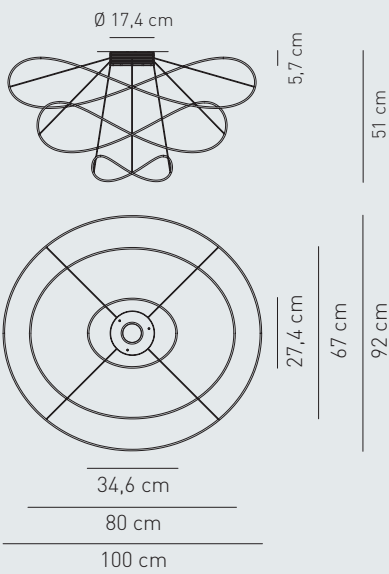

SP HOOPS 2

source integrated **LED** warm light
power 2 x 17.5 W
(up and down light)
output / efficiency 2 x 1230lm - 70lm/W
marks **CE**  IP20

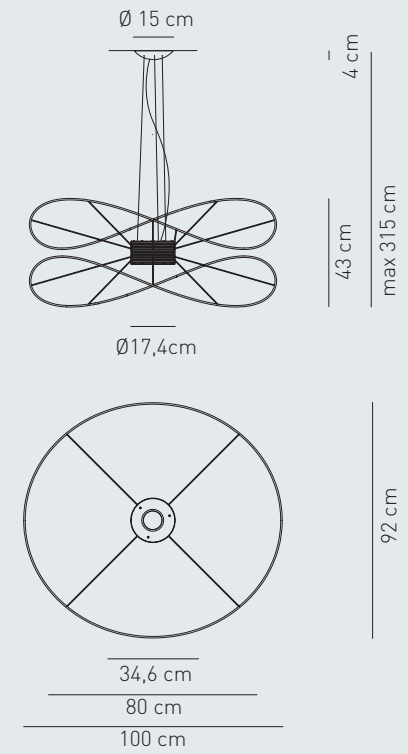

finitura dorata con oro 24K / 24K gold finish

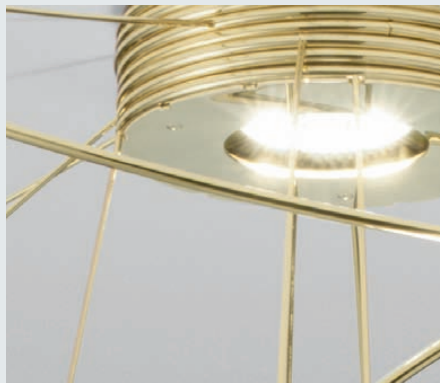

SP HOOPS 3

source integrated **LED** warm light
power 2 x 17.5 W
(up and down light)
output / efficiency 2 x 1230lm - 70lm/W
marks **CE** \oplus IP20

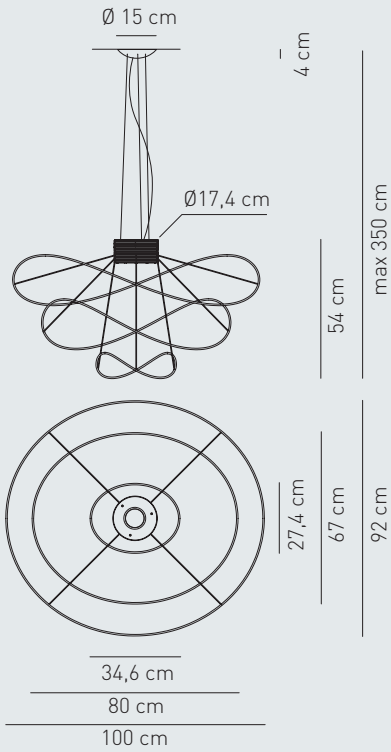

SP HOOPS 4

source integrated **LED** warm light
power 2 x 17.5 W
(up and down light)
output / efficiency 2 x 1230lm - 70lm/W
marks **CE** \oplus IP20

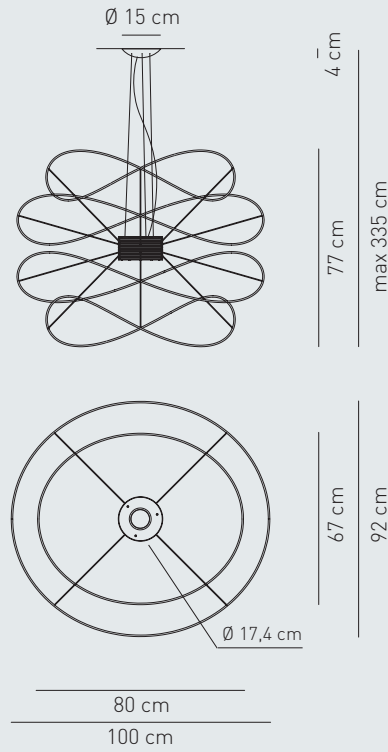

SP HOOPS 6

source integrated **LED** warm light
power 2 x 17.5 W
(up and down light)
output / efficiency 2 x 1230lm - 70lm/W
marks **CE** \oplus IP20

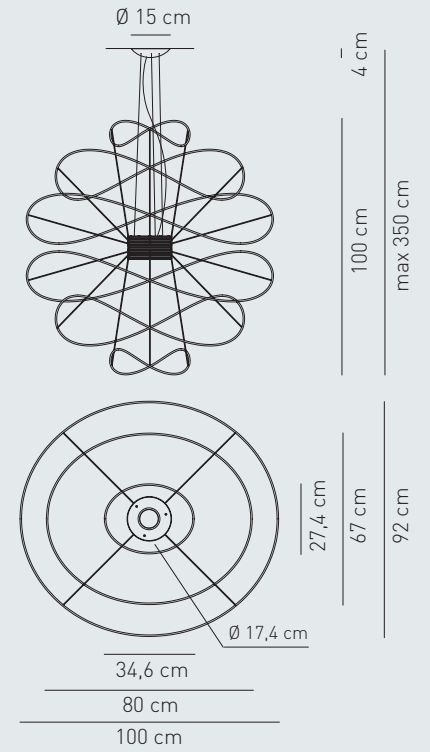

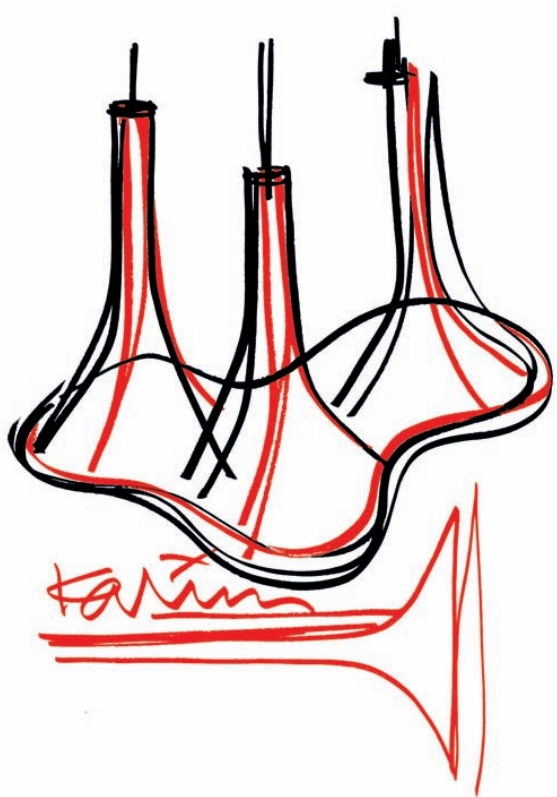

NEW
PINK
GOLD:
BRONZE
NA FIR

NAFIR KARIM RASHID

Collezione di sospensioni e plafoniere a una o tre luci in ABS bianco ad iniezione disponibili nelle versioni esterno cromo/interno bianco, esterno bianco/interno oro, esterno bianco/interno bianco, esterno bronzo/interno bianco (new) e esterno oro rosa/interno bianco (new). Sorgenti luminose a LED con attacco GU10. Downlight ad incasso a tre luci disponibile nelle versioni cromo, oro e bianco con sorgente luminosa a LED con attacco GU5.3.

Collection of hanging lamps and ceiling lamps with one or three lights in white injection moulded ABS, available in these versions: chrome on the outside/white on the inside; white on the outside/gold on the inside; white on the outside/white on the inside; bronze on the outside/white on the inside (new); and pink gold on the outside/white on the inside (new). LED light sources with GU10 fitting. Built-in downlight with three lights available in chrome, gold and white versions with LED light source with GU5.3 fitting.

Kollektion von Hängelampen und Deckenleuchten mit einem oder drei Leuchtkörpern in weißem ABS-Spritzguss. Erhältlich in den Ausführungen außen Chrom/innen weiß, außen weiß/innen Gold, außen weiß/innen weiß, außen bronze/innen weiß (neu) und außen rotgold/innen weiß (neu). Lichtquellen: LED mit GU10-Anschluss. Die Einbau-Deckenleuchte mit drei Leuchtkörpern ist in den Ausführungen Chrom, Gold und weiß mit LED und GU5.3-Anschluss erhältlich.

Collection de suspensions et plafonniers à une ou trois lumières en ABS blanc à injection disponibles dans les versions : extérieur chromé/intérieur blanc, extérieur blanc/intérieur doré, extérieur blanc/intérieur blanc, extérieur bronze/intérieur blanc (nouveau) et extérieur doré rose/intérieur blanc (nouveau). Sources lumineuses à LED avec bord d'attaque GU10. Downlight encastré à trois lumières disponible dans les versions chromé, doré et blanc avec source lumineuse à LED avec bord d'attaque GU5.3.

Colección de suspensiones y plafones de una o tres luces en ABS blanco por inyección disponibles en las versiones exterior cromo/interior blanco, exterior blanco/interior oro, exterior blanco/interior blanco, exterior bronce/interior blanco (nuevo) y exterior oro rosa/interior blanco (nuevo). Fuentes luminosas de LED con casquillo GU10. Downlight empotrable de tres luces disponible en las versiones cromo, oro y blanco con fuente luminosa de LED con casquillo GU5.3.

Coleção de pendentes e plafons de uma ou três luzes em ABS branco injetado, disponíveis nas seguintes versões: exterior cromo/interior branco, exterior branco/interior ouro, exterior branco/interior branco, exterior bronze/interior branco (new) e exterior ouro rosa/interior branco (new). Fontes luminosas de LED com encaixe GU10. Downlight de embutir com três luzes, disponível nas versões cromo, ouro e branco com fonte luminosa de LED com encaixe GU5.3.

Коллекция из подвесных светильников, плафонов с одной или тремя лампами, изготовленных из АБС-пластика белого цвета. Светильники представлены в пяти вариантах: снаружи хромированный/внутри белый, снаружи белый/внутри золотой, снаружи белый/внутри белый, а также новые версии: снаружи бронзовый/внутри белый и снаружи розово-золотой/внутри белый. Источник света: светодиодные лампы с цоколем GU10. Точечные светильники с тремя лампами имеются в следующих вариантах: хром, золото и белый со светодиодом и цоколем GU5.3.



German
Design Award
NOMINEE 2014







- ^ SP NAFIR 3 RO BC
- < SP NAFIR 1 RO BC
- « PL NAFIR 1 RO BC / SP NAFIR 3 RO BC
- « PG 38-39: SP NAFIR 3 RO BC



^ SP NAFIR 3 BR BC
> SP NAFIR 3 BR BC
SP NAFIR 1 BR BC





^ PL NAFIR 1 BR BC
< PL NAFIR 3 BR BC



^ PL NAFIR 1 RO BC
> PL NAFIR 3 RO BC



TECHNICAL DATA

FINITURE / FINISHINGS



esterno oro rosa / interno bianco (new)
rose gold on the outside / white on the inside (new)



esterno bronzo / interno bianco (new)
bronze on the outside / white on the inside (new)





PL NAFIR 1

base / bulb type	GU10 LED bulbs
power	1 x Max 7.5 W
ilcos	DRPAR LED 
marks	CE  IP20

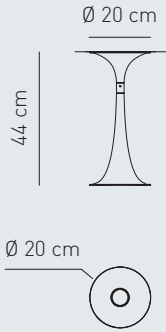
the total height of the bulbs must be between 52 and 62 mm





SP NAFIR 1

base / bulb type	GU10 LED bulbs
power	1 x Max 7.5 W
ilcos	DRPAR LED 
marks	CE  IP20

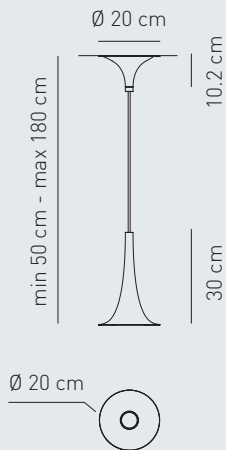
the total height of the bulbs must be between 52 and 62 mm





PL NAFIR 3

base / bulb type	GU10 LED bulbs
power	3 x Max 7.5 W
ilcos	DRPAR LED 
marks	CE  IP20

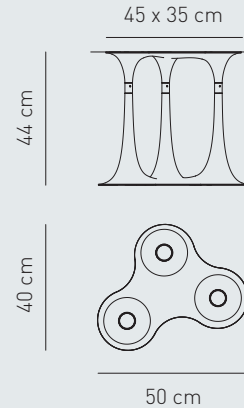
the total height of the bulbs must be between 52 and 62 mm



SP NAFIR 3

base / bulb type	GU10 LED bulbs
power	3 x Max 7.5 W
ilcos	DRPAR LED 
marks	CE  IP20

the total height of the bulbs must be between 52 and 62 mm

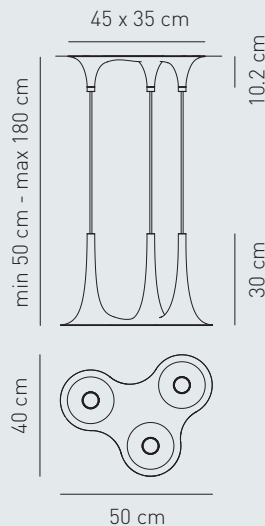

Per prendere visione della collezione completa in tutte le sue finiture, vi preghiamo di riferirvi al catalogo generale Axo Light 2013-2015 o di visitare la sezione "prodotti" su www.axolight.it

The complete collection and all the finishes are available for consultation in the Axo Light 2013-2015 catalogue and in the "products" section on www.axolight.it

Die komplette Kollektion mit allen verschiedenen Ausführungen kann im Hauptkatalog von Axo Light 2013-2015 eingesehen werden oder besuchen Sie die Website www.axolight.it und dort den Teil "Produkte".

A fin de mieux connaître la collection complète dans toutes ses variantes, veuillez consulter le catalogue général Axo Light 2013-2015 ou bien visiter la section «produits» sur www.axolight.it

Para consultar la colección completa en todos los acabados, le rogamos que tome como referencia el catálogo general Axo Light 2013-2015 o visitar la sección "productos" en www.axolight.it

Para visualizar a coleção completa com todos os seus acabamentos, por favor, consulte o catálogo geral Axo Light 2013-2015 ou visite a seção "produtos" em www.axolight.it

С полной коллекцией можно ознакомиться на сайте www.axolight.it в разделе «Products» или в каталоге Axo Light 2013-2015.

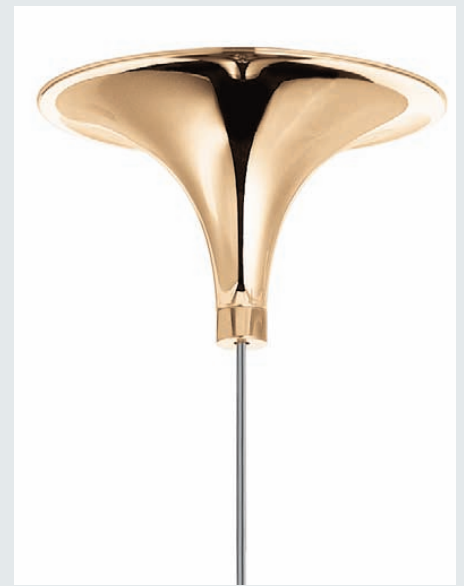

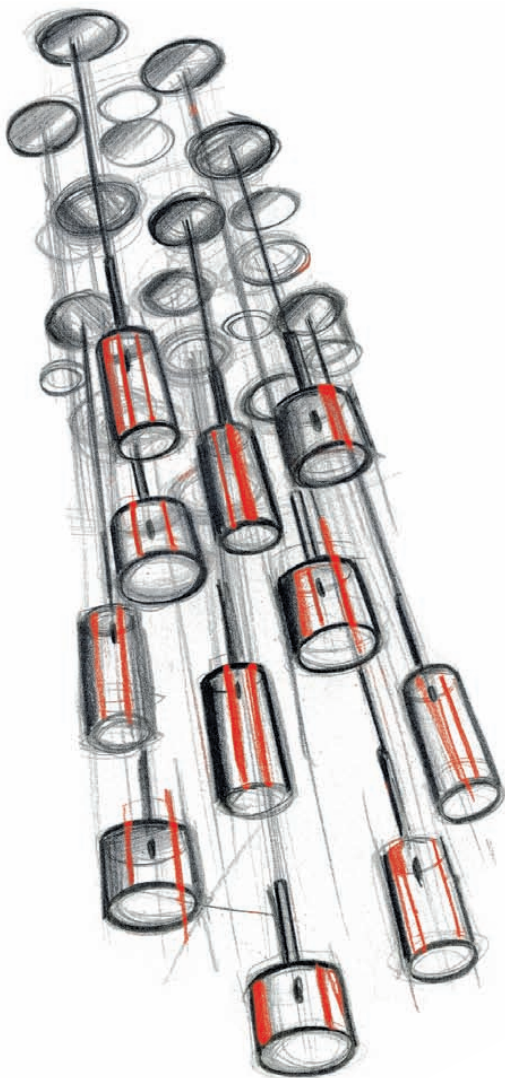

Manuel Vivian

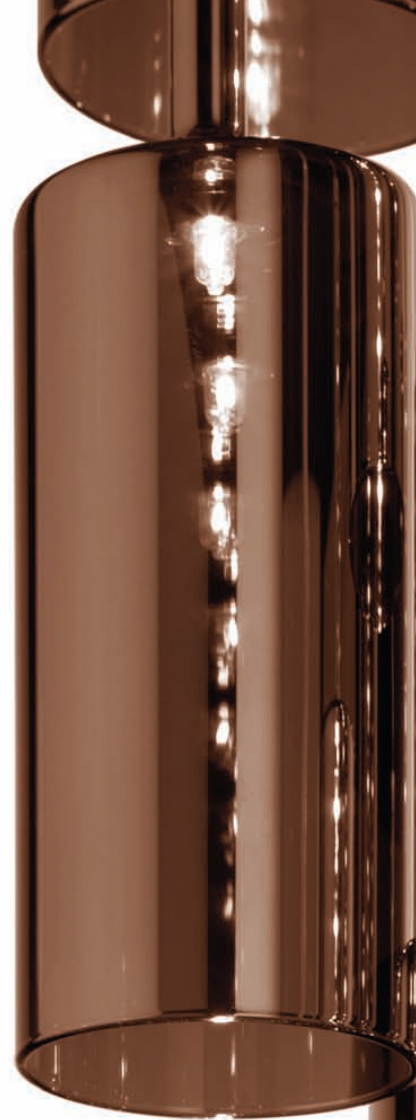

SPILLRAY MANUEL VIVIAN

Collezione completa di lampade in vetro nei colori cristallo, arancio, rosso o grigio con montatura in metallo cromato. Fonte luminosa alogena 12V.

Le sospensioni singole, a tre luci, a sei luci, a dieci luci e a dodici luci sono disponibili anche nel colore bronzo metallizzato (new).

A complete collection of glass lamps available in crystal, orange, red and grey, with chrome-plated metal frame. 12V halogen light source.

The hanging lamps, with one, three, six, ten and twelve lights are also available in metallic bronze (new).

Kollektion von Glasleuchten in den Farben kristall, orange, rot oder grau mit Befestigung auf verchromtem Metall. Lichtquelle: Halogen 12 V. Die Hängelampen mit eins, drei, sechs, zehn und zwölf Leuchtkörpern sind auch in die Farbe metallisierte Bronze (neu) erhältlich.

Collection complète de lampes en verre dans les couleurs cristal, orange, rouge ou gris avec monture en métal chromé. Source lumineuse halogène 12V.

Les suspensions simples, à trois, à six, à dix et à douze lumières sont disponibles aussi en couleur bronze métallisé (nouveau).

Colección completa de lámparas de cristal en los colores cristal, naranja, rojo o gris con estructura de metal cromado. Fuente luminosa halógena 12V. Las suspensiones individuales, de tres, de seis, de diez y de doce luces están disponibles también en el color bronce metalizado (nuevo).

Coleção completa de luminárias de vidro nas cores cristal, laranja, vermelho ou cinza com armação de metal cromado. Fonte luminosa halógena 12V. As suspensões individuais, com três, com seis, com dez e com doze luzes também estão disponíveis na cor bronze metalizado (new).

Коллекция светильников из прозрачного, оранжевого, красного или серого стекла с каркасом из хромированного металла. Источник света: галогенная лампа 12 В. Подвесные светильники с одним, тремя, шестью, десятью или двенадцатью плафонами теперь представлены в новом цвете «металлик».





- < SP SPIL 12
- > SP SPILL 3
- « PG 48-49: SP SPIL 12 (DETAIL)





< SP SPILL M
SP SPILL P
SP SPILL G
> SP SPIL 10





TECHNICAL DATA

FINITURE / FINISHINGS

bronzo metallizzato / metallic bronze (new)



SP SPILL P

base / bulb type G4 halogen
power 1 x Max 20 W
ilcos HSGST/UB 
marks CE \oplus 12V IP20

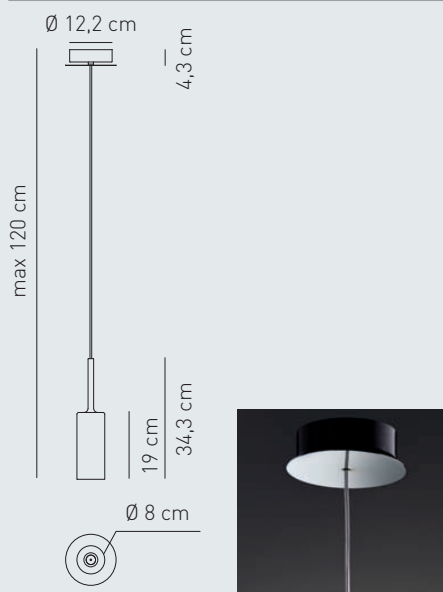

SP SPILL P I

base / bulb type G4 halogen
power 1 x Max 20 W
ilcos HSGST/UB 
marks CE \square 12V IP20

hole \varnothing 4 cm / min depth 10 cm

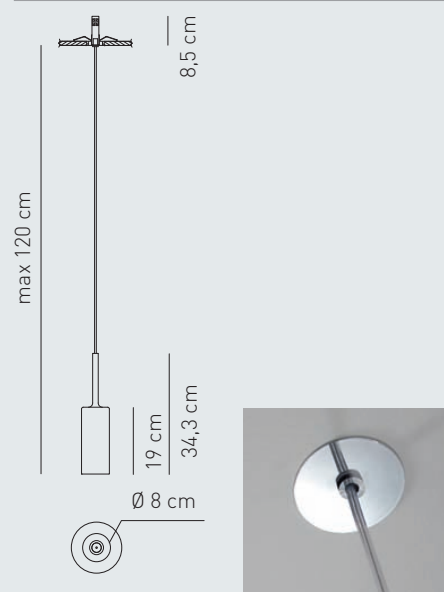

Per prendere visione della collezione completa in tutte le sue finiture, vi preghiamo di riferirvi al catalogo generale Axo Light 2013-2015 o di visitare la sezione "prodotti" su www.axolight.it

The complete collection and all the finishes are available for consultation in the Axo Light 2013-2015 catalogue and in the "products" section on www.axolight.it

SP SPILL M

base / bulb type G4 halogen
power 1 x Max 20 W
ilcos HSGST/UB 
marks CE \oplus 12V IP20

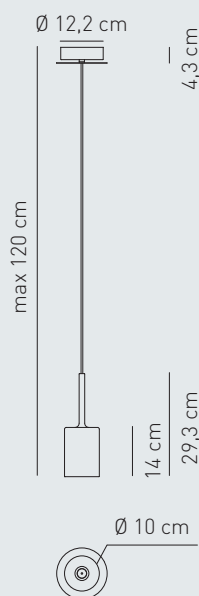



SP SPILL M I

base / bulb type G4 halogen
power 1 x Max 20 W
ilcos HSGST/UB 
marks CE \square 12V IP20

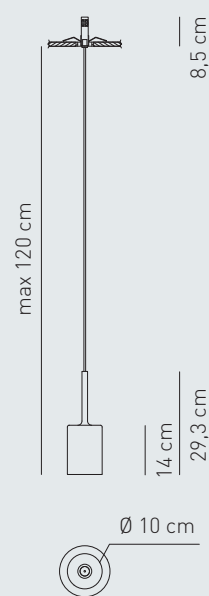
hole \varnothing 4 cm / min depth 10 cm



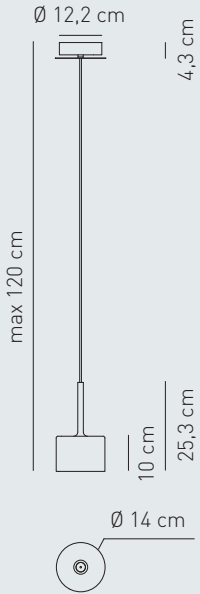

SP SPILL G

base / bulb type G4 halogen
 power 1 x Max 20 W
 ilcos HSGST/UB 
 marks   12V IP20





SP SPILL G I

base / bulb type G4 halogen
 power 1 x Max 20 W
 ilcos HSGST/UB 
 marks   12V IP20

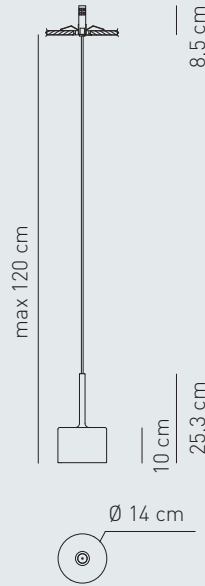
hole \varnothing 4 cm / min depth 10 cm



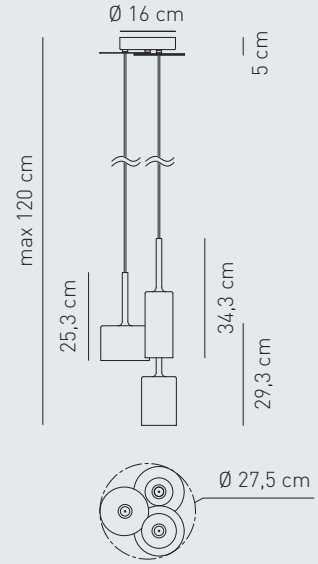

SP SPILL 3

base / bulb type G4 halogen
 power 3 x Max 20 W
 ilcos HSGST/UB 
 marks   12V IP20



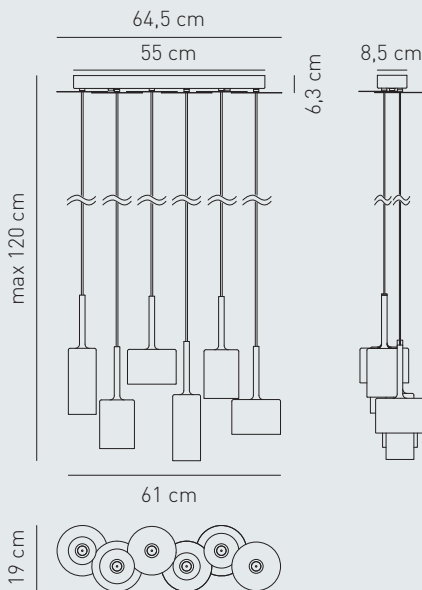

SP SPILL 6

base / bulb type G4 halogen
 power 6 x Max 20 W
 ilcos HSGST/UB 
 marks   12V IP20



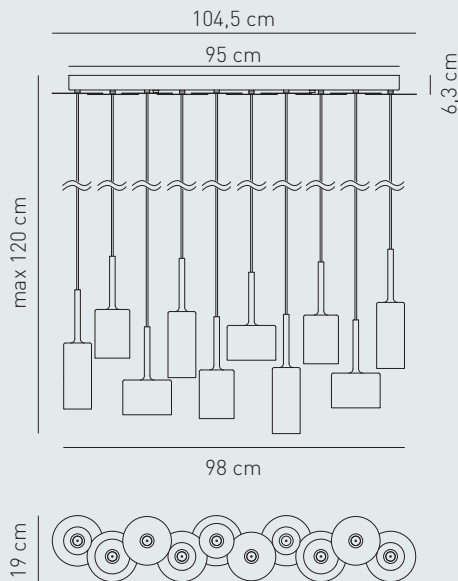

SP SPILL 10

base / bulb type G4 halogen
 power 10 x Max 20 W
 ilcos HSGST/UB 
 marks   12V IP20



SP SPILL 12

base / bulb type G4 halogen
 power 12 x Max 20 W
 ilcos HSGST/UB 
 marks   12V IP20

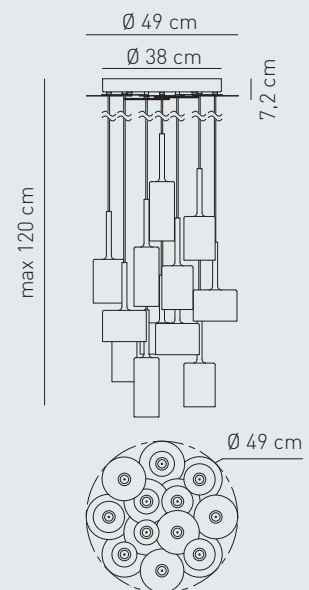

EELc compatibility

Energy Efficiency Label compatibility

Gli apparecchi Axo Light sono compatibili con lampadine etichettate con le classi energetiche del regolamento ENERGY LABELLING, eventualmente disponibili in commercio e previa verifica dimensionale. I dati EELc sono rilevati dai siti internet dei principali produttori di lampadine, la cui produzione è soggetta a possibili variazioni.

❶ Gli apparecchi il cui codice termina con "LED" sono muniti di lampade a LED integrate A, A+, A++ non sostituibili.

La classe energetica in grassetto è quella della lampadina con cui è venduto l'apparecchio.

The Axo Light luminaires are compatible with bulbs labelled with the energy classes of the ENERGY LABELLING regulation, if available in trade and after dimensional check.

❶ The luminaires in which code there is the "LED" abbreviation contains built in LED lamps A, A+, A++, that cannot be changed.

The bold font energy class is that of the bulb which the luminaire is sold with.

Le informazioni qui riportate, riguardo le Classi Energetiche delle lampadine, non sono esaustive di tutte i tipi effettivamente reperibili sul mercato della Area Economica Europea.

The information regarding the Energy Classes of the bulbs are not exhaustive about the actual whole range available on the Economic European Area market.

LISTA CODICI EELc / EELc CODE LIST

ARTICLE CODE EELc

FEDORA

FAFEDORAXXXGU1	A, A+, A++
SPFEDOR1XXXXGU1	A, A+, A++
SPFEDOR3XXXXGU1	A, A+, A++
SPFEDOR6XXXXGU1	A, A+, A++
SPFEDOR7XXXXGU1	A, A+, A++
SPFEDO12XXXXGU1	A, A+, A++

HOOPS

PLHOOP5XXXXLED	❶
SPHOOP5XXXXLED	❶

MELTING POT

APMELTIN	E, D, C, B, A, A+, A++
SPMELT60	E, D, C, B, A, A+, A++
SPMEL120	E, D, C, B, A, A+, A++
SPMEL115	E, D, C, B, A, A+, A++

NAFIR

PLNAFIR1XXXXGU1	A, A+, A++
PLNAFIR3XXXXGU1	A, A+, A++
SPNAFIR1XXXXGU1	A, A+, A++
SPNAFIR3XXXXGU1	A, A+, A++

SPILLRAY

SPSPILLPXXXX12V	C, B
SPSPILPIXXX12V	C, B
SPSPILLMXXX12V	C, B
SPSPILMIXXX12V	C, B
SPSPILLGXXX12V	C, B
SPSPILGIXXX12V	C, B
SPSPILL3XXX12V	C, B
SPSPILL6XXX12V	C, B
SPSPIL10XXX12V	C, B
SPSPIL12XXX12V	C, B



I nostri prodotti sono tutti sottoposti alle prove di sicurezza elettrica e conformi alle Direttive Europee, LVD 2006/95/EC, EMC 2004/108/EC, IEC 62471 (ove previsto) e alla norma EN 60598-1.

All our products undergo electric safety tests and comply with ECC Directive 2006/95/EC, EMC 2004/108/EC, IEC 62471 (where provided) and with rule EN 60598-1.



Solo isolamento fondamentale; le parti conduttrici accessibili sono collegate ad un conduttore di terra. Messa a terra obbligatoria.

Basic insulation, accessible conductors are earthed. Earthing is compulsory.



Sistema a doppio isolamento; messa a terra esclusa.

Double insulation.
Earthing: excluded.

IPXY

Grado di protezione contro corpi solidi X - e contro i liquidi Y.

Protection rating against solid bodies X - against liquids Y.

Verificare dimensioni ed ingombri delle lampadine LED e CFL self ballasted consigliate nel presente catalogo, prima dell'acquisto. Fornitura lampadine LED su richiesta.

Before any purchase, please verify size and dimensions of the LED and CFL self-ballasted bulbs recommended in this catalogue. Supply of LED bulbs on request.

Le schede tecniche dei prodotti Axo Light sono scaricabili direttamente dal nostro sito: www.axolight.it

Axo Light technical sheets can be downloaded directly from our website: www.axolight.it

Axo Light si riserva il diritto di apportare ai modelli, senza alcun preavviso, qualsiasi modifica ritenesse opportuna. Axo Light non risponde per eventuali danni a persone o cose causati da una non corretta installazione dei propri apparecchi d'illuminazione. I dati riportati sono puramente indicativi; è possibile che siano riportati degli errori di stampa.

Axo Light reserves itself the right to introduce any changes to its own models, without prior notice. Axo Light is not liable for injuries or damage due to the incorrect installation of its fixtures. The details given here are intended purely as guidance as errors may have occurred during the printing process.

AXOLIGHT NEWS 2015-1

Art director
Lorenzo Truanti
**Coordination
and editing**
Fabrizio Cettina

Graphic design
+fortuna / Paola Fortuna
Photo credits
Florindo Romandini
Studio Pointer srl
Studio Varianti

Photolitho
Graficart srl
Fotolito Quattrofoglio
Studio Varianti
Printed
Graficart srl

Printed
in January 2015

AXO LIGHT SRL

via Moglianese 44
30037 Scorzè
Venezia, Italy
t +39 041 5845193
f +39 041 5845060
axolight@axolight.it
www.axolight.it

AXO LIGHT USA INC.

22 Shelter Rock Lane STE# 104
Danbury, CT, 06810 USA
t +1 (203) 730 0452
f +1 (203) 730 0460
info@axolightusa.com
www.axolightusa.com

AXO LIGHT ASIA LIMITED

RM305-306, Office Building
No.2 Tiantaiyi Road
Science Town, Luogang District
510663 Guangzhou - PRC
t +86 20 38316571
f +86 20 38251165
axo.asia@axolight.asia
www.axolight.it

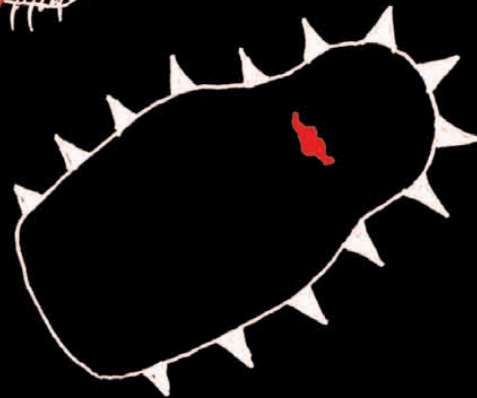

Three Sisters
FEDORA