



AXO[®] 2013-2015
LIGHT

 **2013-2015**

AXOLIGHT 2013-2015

Art director

Lorenzo Truant

Graphic design

+fortuna

Paola Fortuna with Peppe Clemente

Artworks by Tullio Sila

except pg. 4, Karim Rashid sketch

Coordination and editing

Fabrizio Cettina

Photo credits

Florindo Romandini

except

pg. 4 > 11, Studio Varianti

Photolitho

Fotolito Quattrifoglio

except

pg. 4 > 11, Studio Varianti

Printed

Graficart

Arti Grafiche s.r.l.

Thanks to

Bonaldo

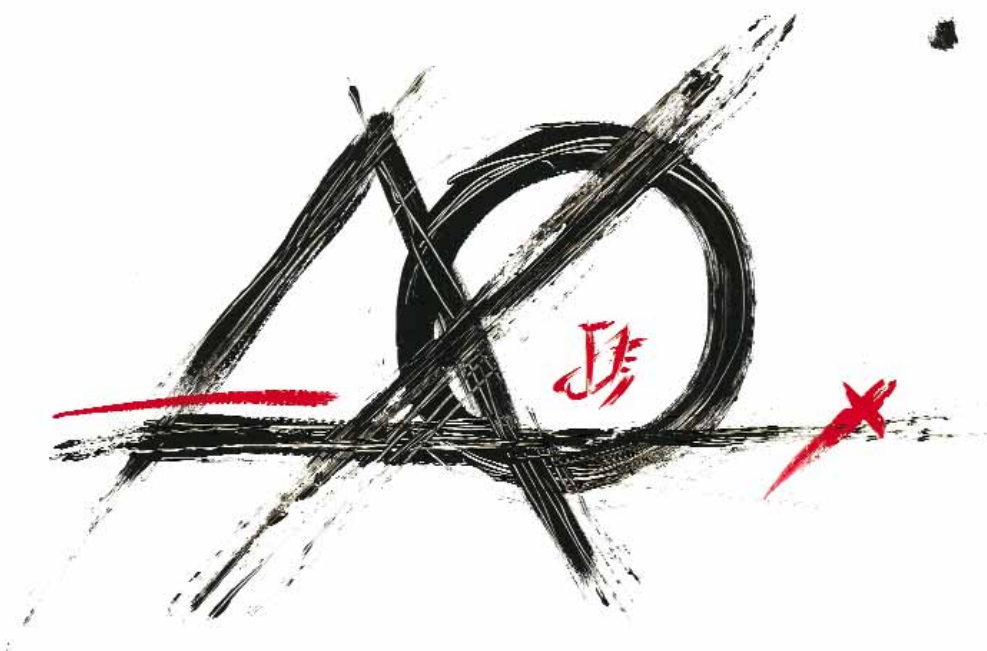

INDEX

36	ALRISHA
94	AURA
102	AX20
166	BALIOS
130	BLUM
80	CLAVIUS
172	CRYSTAL SPOTLIGHT
66	EXPLO
20	FAIRY
148	KOSHI
152	KUDLIK
30	LEIJA
138	MARYLIN
52	MUSE
4	NAFIR
88	NELLY/NELLY STRAIGHT
108	OBI
114	POLIA
128	SHARAV
168	SHIRAZ
162	SLIGHT
40	SPILLRAY
16	SPIRY
134	STORMY
154	SUBZERO
74	SUNSHADE
144	UKIYO
124	URIEL
120	VASILY
175	TECHNICAL DATA

Collezione di sospensioni, plafoniere ad una o tre luci in ABS bianco ad iniezione disponibili nelle versioni esterno cromo/interno bianco, esterno bianco/interno oro, esterno bianco/interno bianco. Sorgenti luminose a LED con attacco GU10. Downlight ad incasso a tre luci disponibile nelle versioni cromo, oro e bianco con sorgente luminosa a LED con attacco GU5.3.

Collection of suspensions and ceiling lamps with one or three lights in injection moulded white ABS, available in the chrome exterior/white interior, white exterior/gold interior, white exterior/white interior versions. LED light sources with GU10 fitting. Recessed downlight with three lights, available in the chrome, gold and white versions with LED light source and GU5.3 fitting.

Kollektion von Pendel- und Deckenleuchten, ein- oder dreiflammig. Material bestehend aus Spritzguß-Kunststoff ABS; erhältlich in den Ausführungen: außen chromfarben/innen weiß - außen weiß/innen goldfarben - außen weiß/innen weiß. Pendelleuchten mit Lampenfassung GU10 für LED Retrofitleuchtmittel (nicht inbegriffen). Einbau-Deckenleuchten dreiflammig; erhältlich in den Ausführungen chromfarben, goldfarben und weiß. Lampenfassung GU5.3 für LED Retrofitleuchtmittel (nicht inbegriffen)

Collection de suspensions, plafonniers à une ou trois ampoules en ABS blanc moulé à injection, disponibles en version extérieur chromé/intérieur blanc, extérieur blanc/intérieur doré, extérieur blanc/intérieur blanc. Ampoules LED à culot GU10. Downlight encastrable à trois ampoules disponible en version chrome, dorée et blanche, avec ampoule LED à culot GU5.3.

Colección de suspensiones y plafones de una o tres luces en ABS blanco de inyección disponibles en las versiones con exterior cromo/interior blanco, exterior blanco/interior oro, exterior blanco/interior blanco. Fuentes luminosas de LED con portalámparas GU10. Downlight empotrable de tres luces disponible en las versiones cromo, oro y blanco con fuente luminosa de LED con portalámparas GU5.3.

Coleção de luminárias, pendentes, arandelas com uma ou três luzes de ABS branco a injeção, disponíveis nas versões exterior cromo/interior branco, exterior branco/interior ouro, exterior branco/interior branco. Fontes luminosas LED com acoplamento GU10. Downlight de embutir com três luzes, disponível nas versões cromo, ouro e branco, com fonte luminosa LED com acoplamento GU5.3.

Коллекция из подвесных светильников, плафонов с одной или тремя лампами, изготовленных из АБС-пластика белого цвета. Светильники представлены в трех вариантах: снаружи хромированный/внутри белый, снаружи белый/внутри золотой, снаружи белый/внутри белый. Светодиодные лампы с цоколем GU10. Точечные светильники с тремя лампами имеются в следующих вариантах: хром, золото и белый со светодиодом и цоколем GU5.3

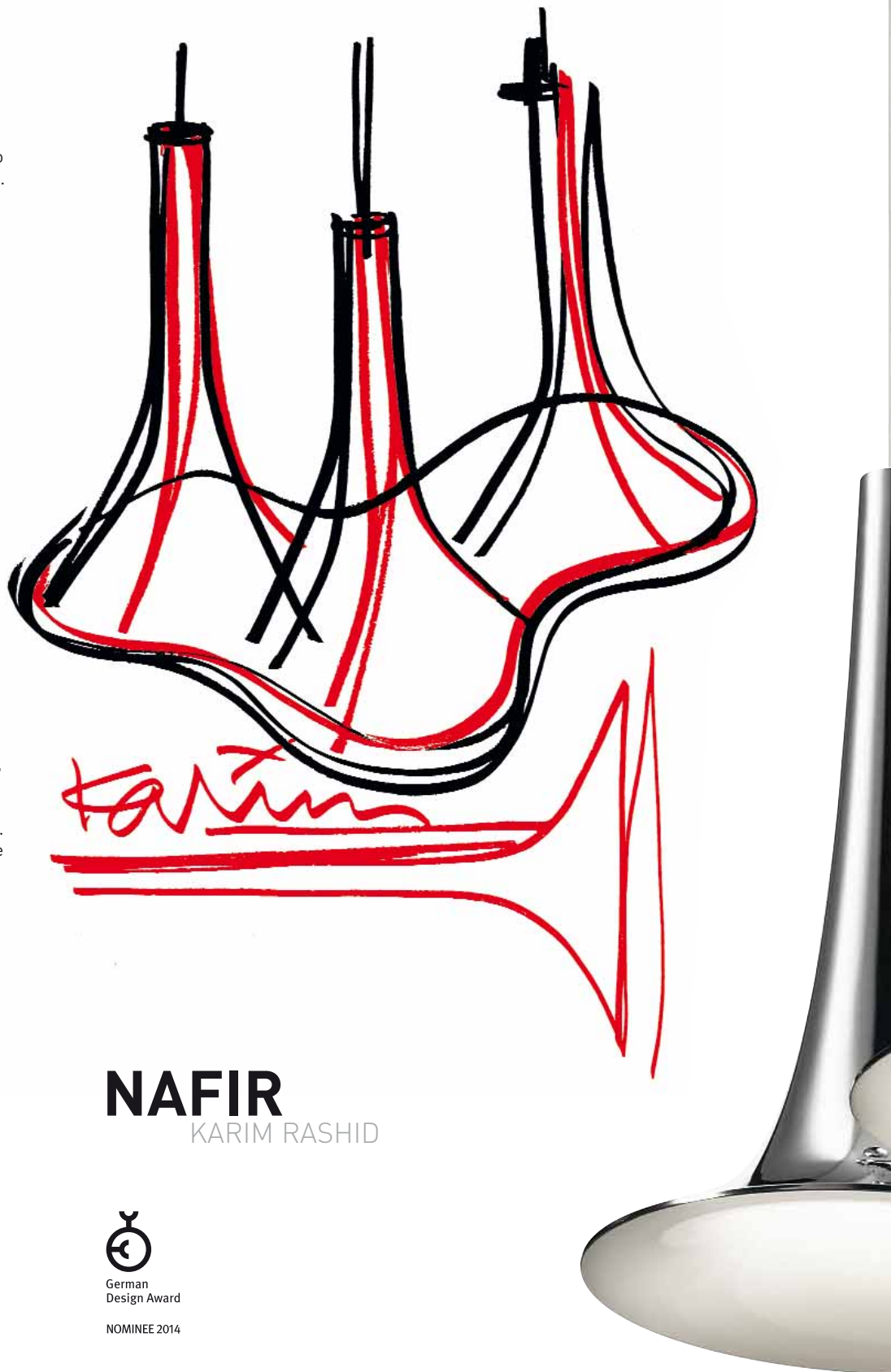

NAFIR

KARIM RASHID



German
Design Award

NOMINEE 2014







^ SP NAFIR 1 CR BC
SP NAFIR 3 CR BC
< SP NAFIR 1 CR BC
<< PG 4-5: SP NAFIR 1 CR BC
SP NAFIR 3 CR BC



^ SP NAFIR 1 BC OR
SP NAFIR 3 BC OR
> SP NAFIR 1 BC OR







^ SP NAFIR 3 BC BC
< SP NAFIR 3 BC BC





- ^ PL NAFIR 1 BC BC
- ^ PL NAFIR 1 BC OR
- > PL NAFIR 3 BC OR
- < PL NAFIR 3 CR BC
- PL NAFIR 1 CR BC





< PL NAFI 3 | BC CR
PL NAFI 3 | BC OR
PL NAFI 3 | BC BC
> PL NAFI 3 | BC CR





Sospensione in alluminio curvato a forma di spirale verniciato bianco RAL 9016 opaco con sorgente luminosa alogena oppure fluorescente

Aluminium suspension with spiral-shaped curve, painted in RAL 9016 matt white with halogen or fluorescent light source.

Hängeleuchte aus matt weiß (RAL 9016) lackiertem Aluminium in Spiralform mit Halogen- oder Leuchtstofflampe.

Suspension en aluminium courbé en forme de spirale, laqué blanc RAL 9016 opaque avec ampoule halogène ou fluorescente.

Suspensión en aluminio curvado con forma de espiral pintado blanco RAL 9016 mate con fuente luminosa halógena o fluorescente.

Coleção de luminárias, pendentes de alumínio curvado, de forma espiral branca, RAL 9016 fosco com fonte luminosa halógena ou fluorescente.

Подвесной светильник из алюминия, изогнутого в форме спирали, окрашен матовой белой краской RAL 9016 с галогенной или люминесцентной лампой.

SPIRY

GIOVANNI BARBATO









^ SP SPIRY
< SP SPIRY
« PG 16-17: SP SPIRY (DETAIL)

Collezione di lampade con struttura in alluminio cromato nelle tipologie da soffitto, anche nella variante incasso, da parete e sospensioni singole oppure multiple. Diffusore in cristallo disponibile anche in colore ambra e grigio fumè. Sorgenti luminose a LED.

Collection of lamps with chrome aluminium frame. Different typologies available: ceiling lamp - including recessed version, wall lamp and single or multiple suspensions. Glass diffuser also available in amber and smoky grey. LED light sources.

Leuchtenkollektion mit Gestell aus verchromtem Aluminium in den Ausführungen als Deckenleuchte (auch als Einbaumodell), sowie Wand- und Hängeleuchte, einzeln oder auch in mehrfachen Zusammenstellungen. Kristallschirm auch in den Farben Bernstein und Rauchgrau erhältlich. Mit integriertem LED Leuchtmittel.

Collection de luminaires à la structure en aluminium chromé avec plafonnier même encastrable, appliques et suspensions simples ou multiples. Diffuseur en cristal disponible notamment en ambre et gris fumé. Ampoules LED.

Colección de lámparas con estructura en aluminio cromado en las tipologías de techo, incluso en la versión empotrable, de pared y suspensiones individuales o múltiples. Difusor en cristal disponible también en color ámbar y gris ahumado. Fuentes luminosas de LED.

Coleção de luminárias com estrutura de alumínio, nas versões de teto também com a variante de embutir, de parede, e pendentes simples ou múltiplas. Difusor de cristal disponível também na cor âmbar e cinza fumê. Fontes luminosas LED.

Коллекция светильников с конструкцией из хромированного алюминия. Типы светильников: потолочные, в том числе встраиваемые, настенные, одиночные подвесные светильники или композиции из них. Рассеиватель из стекла, в наличии имеется также янтарный и дымчато-серый цвета. Светодиодные лампы.



FAIRY

MANUEL VIVIAN







^ SP FAIR 12
< SP FAIR 18 + ANELLO FAIRY 060
+ ANELLO FAIRY 100
« PG 21: SP FAIRY



^ SP FAIR 12 + ANELLO FAIRY 060
+ ANELLO FAIRY 100
> SP FAI 12 R







< SP FAIRY
> AP FAIRY



^ FA FAIRY
> PL FAIRY



^ PL FAIRY I
< PL FAIRY
> FA FAIRY





Collezione costituita da sospensione e lampada da terra in alluminio verniciato bianco RAL 9016 raggrinzato con sorgente luminosa fluorescente.

Aluminium suspension and floor lamp painted in RAL 9016 wrinkled white finish. Fluorescent light source.

Kollektion von Hänge- und Bodenteuchten aus weiß RAL 9016 lackiertem Aluminium mit Leuchtstofflampe.

Collection de suspensions et lampadaires en aluminium laqué blanc RAL 9016 plissé avec ampoule fluorescente.

Colección formada por suspensión y lámpara de pie en aluminio pintado blanco RAL 9016 rugoso con fuente luminosa fluorescente.

Coleção de luminárias constituída por pendentes e luminária de chão em alumínio branco RAL 9016 enrugado, com fonte luminosa fluorescente.

Коллекция, состоящая из подвесного и напольного светильников из алюминия, окрашенных белой краской RAL 9016 со складчатым эффектом и люминесцентной лампы.

LEIJA

CAMBI-SCATENA-TURINI









^ SP LEIJA
< SP LEIJA
« PG 30-31: PT LEIJA (DETAIL)



^ PT LEIJA (DETAIL)
> PT LEIJA



Collezione costituita da sospensione e applique in alluminio verniciato bianco RAL 9016 raggrinzato. Sospensione con sorgente luminosa alogena o fluorescente; applique con sorgente luminosa LED disponibile con o senza scatola di installazione a parete.

Collection that includes an aluminium suspension and wall lamp painted in RAL 9016 wrinkled white finish. Suspension with halogen or fluorescent light source; wall lamp with LED light source with or without wall mounting box.

Kollektion von Hänge- und Wandleuchten aus weiß (RAL 9016) gefältelt lackiertem Aluminium. Hängeleuchte mit Halogen- oder Leuchtstofflampe; Wandleuchte mit LED-Lampe, erhältlich mit oder ohne Schachtel zur Montage an der Wand.

Collection de suspensions et appliques en aluminium laqué blanc RAL 9016 plissé. Suspension avec ampoule halogène ou fluorescente, applique avec ampoule LED disponible avec ou sans boîtier d'installation murale.

Colección formada por suspensión y aplique en aluminio pintado blanco RAL 9016 rugoso. Suspensión con fuente luminosa halógena o fluorescente; aplique con fuente luminosa LED disponible con o sin caja de instalación de pared.

Coleção de luminárias constituídas por pendentes e arandelas de alumínio branco RAL 9016 enrugado. Pendentes com fonte luminosa halógena ou fluorescente; arandela com fonte luminosa LED, disponível com ou sem caixa de instalação na parede.

Коллекция, состоящая из подвесного и настенного светильников из алюминия, окрашенных белой краской RAL 9016 со складчатым эффектом. Подвесной светильник с галогенной или люминесцентной лампой; настенный светильник со светодиодом и коробкой для установки на стене или без нее.

ALRISHA

BRIAN RASMUSSEN

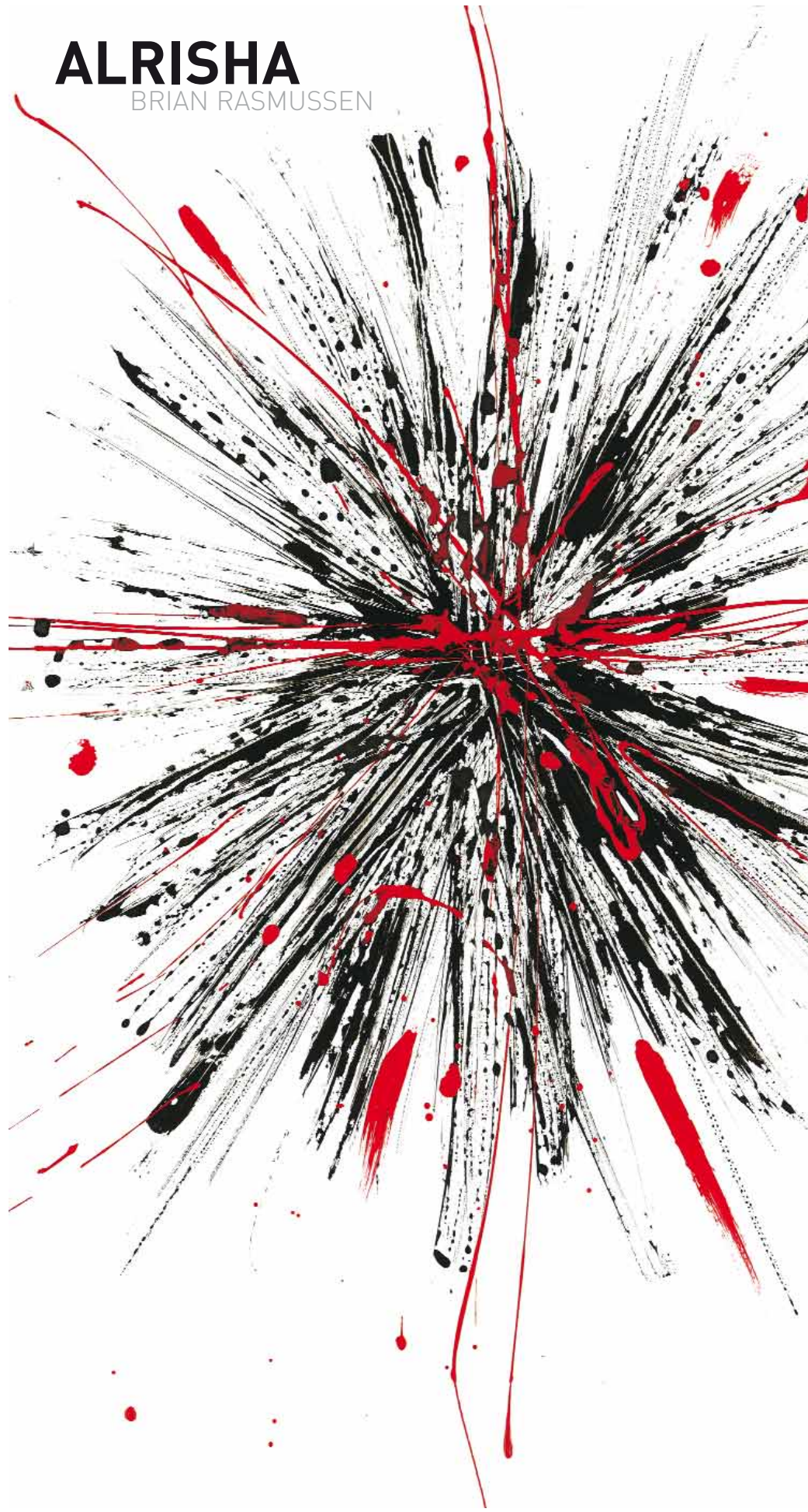







- ^ AP ALRISP
- < AP ALRISH
- « SP ALRISH / AP ALRISH
- « PG 37: SP ALRISH (DETAIL)

Collezione completa di lampade in vetro nei colori cristallo, arancio, rosso o grigio con montatura in metallo cromato. Fonte luminosa alogena 12V.

Complete collection of glass lamps in crystal, orange, red or grey with chrome metal frame. 12V halogen light source.

Komplette Glasleuchtenkollektion, die in den Farben Kristall, Orange, Rot oder Grau mit verchromter Metall-Aufhängung verfügbar ist. Mit 12-V-Halogenlampe.

Collection complète de lampes en verre dans les tons cristal, orange, rouge ou gris avec structure en métal chromé. Ampoule halogène 12V.

Colección completa de lámparas en vidrio de color cristal, naranja, rojo o gris con estructura en metal cromado. Fuente luminosa halógena de 12V.

Coleção completa de luminárias em vidro nas cores cristal, laranja, vermelho ou cinza com armação em metal cromado. Fonte luminosa halógena 12V.

Полная коллекция светильников из прозрачного, оранжевого, красного или серого стекла с каркасом из хромированного металла. Галогенная лампа 12 В.

SPILLRAY

MANUEL VIVIAN

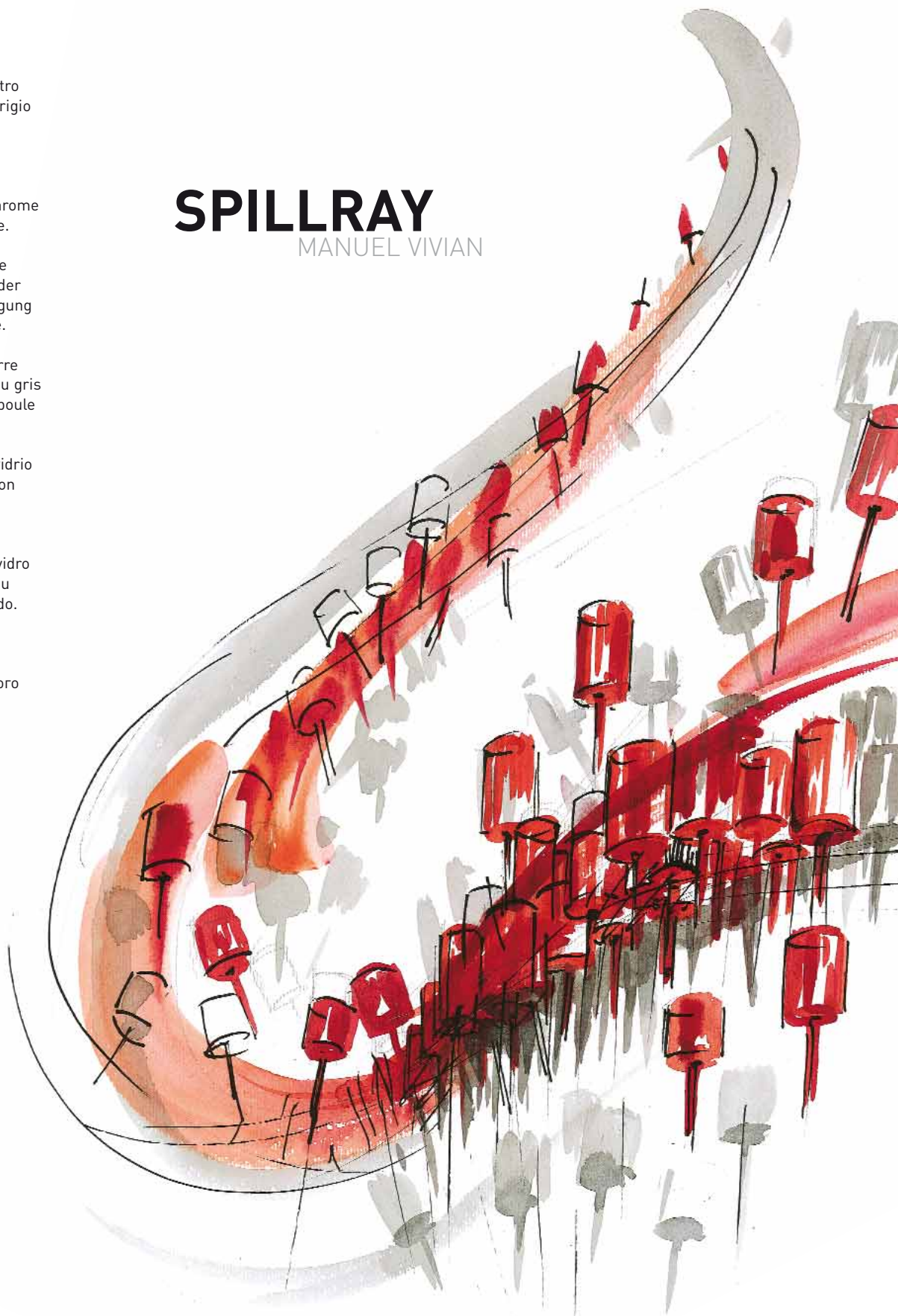





- > SP SPILL 3
- » SP SPILL M
- SP SPILL G
- SP SPILL P
- < SP SPIL 12
- « PG 41: SP SPIL 12 (DETAIL)
- √ SP SPIL 10





^ AP SPILLR
> SP SPILL 6







^ SP SPIL 20
< SP SPIL 30 / LT SPILL P



^ SP SPIL 26
> SP SPIL 26 (DETAIL)







^ LT SPILL P / LT SPILL G
< LT SPILL G
« PL SPIL G I / PL SPIL M I / PL SPIL P I



Collezione di lampade con struttura
metallica bianca e rivestimento in tessuto
elasticizzato, sfoderabile e lavabile.
Varie tipologie e misure disponibili.

Collection of lamps with white metal
frame. Removable and washable stretch
fabric cover. Various typologies and sizes
available.

Leuchtenkollektion mit weißer Metall-
Aufhängung und elastischem,
abziehbarem und waschbarem Stoff.
Erhältlich in verschiedenen Ausführungen
und Größen.

Collection de lampes avec structure
métallique blanche et revêtement en tissu
élastique, amovible et lavable. Plusieurs
modèles et dimensions disponibles.

Colección de lámparas con estructura
metálica blanca y revestimiento en tejido
elastificado y lavable.
Se encuentran disponibles varias tipologías
y medidas.

Coleção de luminárias com estrutura
metálica branca e revestimento de tecido
elástico, removível e lavável. Várias versões
e medidas disponíveis.

Коллекция светильников с белым
металлическим каркасом и съемным
моющимся абажуром из эластичной
ткани. Предлагаются различные типы
и размеры.

MUSE

SANDRO SANTANTONIO



MUSE MULTICOLOR: AS AWARDED
BY THE CHICAGO ATHENAEUM:
MUSEUM OF ARCHITECTURE AND DESIGN.
IN THE PERMANENT DESIGN COLLECTION
OF THE CHICAGO ATHENAEUM: MUSEUM
OF ARCHITECTURE AND DESIGN.







^ PL MUSE 40 / PL MUSE 60
PL MUSE 80 / PL MUS 120
< PL MUS 120
« PG 53: PL MUSE 80 (DETAIL)



^ SP MUSE / PL MUSE 80 | PL MUSE 80 / PL MUS 120
PL MUSE 80 / SP MUSE
SP MUSE
> PL MUSE 80 (DETAIL)







^ PL MUSE 40 FI / PL MUSE 60 FI
PL MUSE 80 FI / PL MUS 120 FI (FIORE)
< PL MUSE 40 ST / PL MUS 120 ST (STICKS)

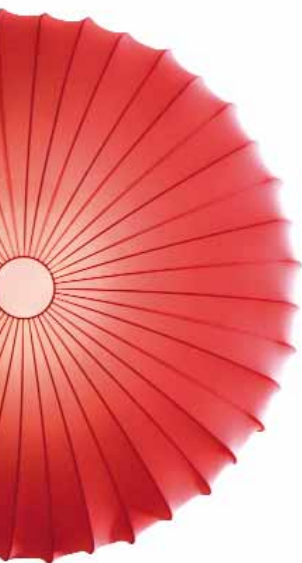
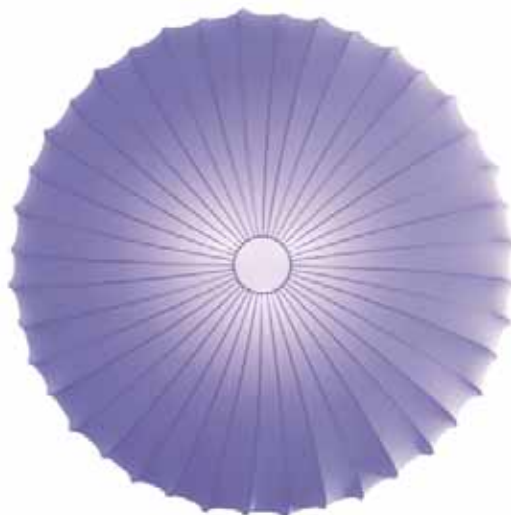

MUSE COLOURS
AZZURRO | LIGHT BLUE
BLU | DARK BLUE
STICKS | STICKS
ARANCIO | ORANGE
VERDE | GREEN
GIALLO | YELLOW
VIOLA | VIOLET
ROSA | PINK
ROSSO | RED
FUCSIA | FUCHSIA
BIANCO | WHITE
FIORE | FLOWER
MULTICOLORE | MULTICOLOUR

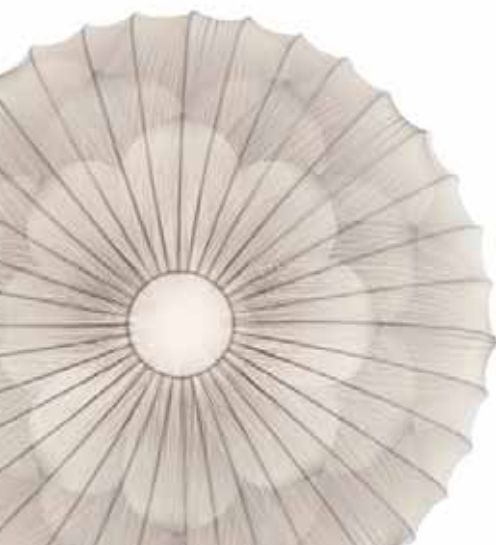
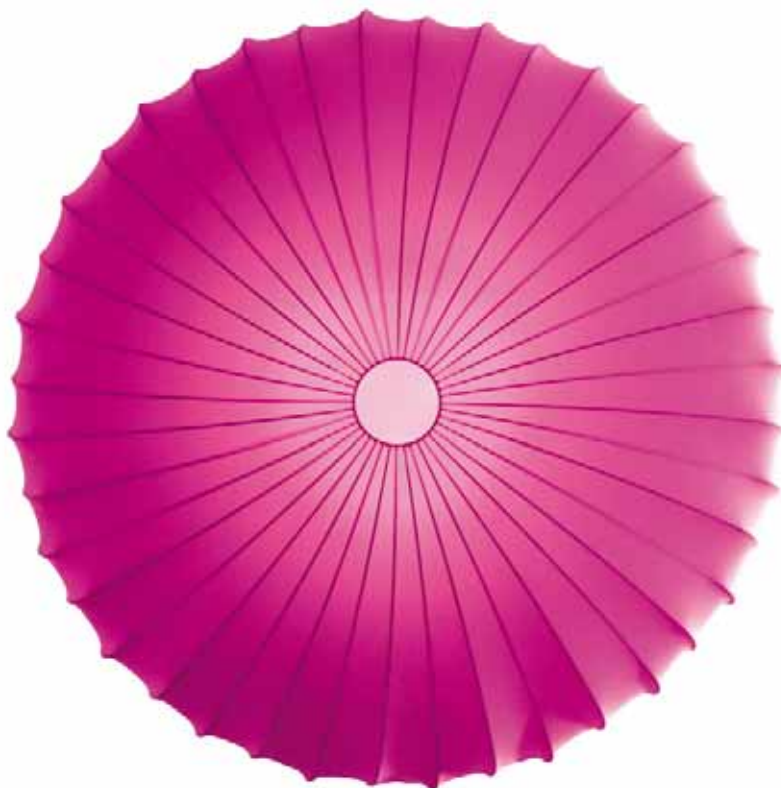





^ SP MUSE 25
> LT MUSE G / SP MUSE 60







^ PL MU 120 Q / PL MUS 60 Q
< LT MUSE P / LT MUSE G
« LT MUSE P / PL MUS 60 Q

Collezione di lampade a sospensione con montatura in metallo verniciato bianco e acciaio, con barre in vetro di Murano lavorate a mano disponibili con interno rosso o bianco, di lunghezza 53 cm. Sorgente luminosa alogena lineare con attacco R7S. Possibilità di composizioni personalizzate.

Collection of suspensions with white painted metal and steel frame and hand-made Murano glass bars, available with red or white interior, 53 cm long. Linear halogen light source with R7S fitting. Customised compositions possible.

Hängeleuchten-Kollektion mit Aufhängung aus weiß lackiertem Metall und Stahl mit handgefertigten Murano-Glasbalken. Die Glasbalken sind in ihrem Inneren rot oder weiß und 53 cm lang. Lineare Halogenlichtquelle mit R7S-Fassung. Es besteht die Möglichkeit individueller Zusammenstellungen.

Collection de suspensions avec structure en métal laqué blanc et acier, barres en verre de Murano fabriquées à la main, disponibles avec intérieur rouge ou blanc, d'une longueur de 53 cm. Ampoule halogène linéaire avec culot R7S. Possibilité de compositions personnalisées.

Colección de lámparas de suspensión con montura en metal pintado blanco y acero, con barras en vidrio de Murano realizadas a mano, disponibles con interno rojo o blanco, de 53 cm de longitud. Fuente luminosa halógena lineal con portalámparas R7S. Posibilidad de composiciones personalizadas.

Coleção de luminárias pendentes com armação em metal envernizado branco em aço, com barras de vidro de Murano feitas a mão, disponíveis com interior vermelho ou branco, comprimento de 53 cm. Fonte luminosa halógena linear com ligação R7S. Possibilidade de composições personalizadas.

Коллекция подвесных светильников с каркасом из окрашенного металла белого цвета и стали с обработанными вручную муранскими стеклянными рейками, предлагается с красной или белой внутренней основой, длина 53 см. Линейная галогенная лампа с цоколем R7S. Возможны индивидуальные композиции по заказу.

EXPLO

MANUEL VIVIAN









^ SP EXP Q 10
< SP EXPL 10
« PG 66-67: SP EXPL 10 (DETAIL)



^ SP EXPL0 5 (DETAIL)
> SP EXP Q 10







^ SP EXPL I 5 (x 5) + 5 V EXPLO (x 5)
+ 50 INTERM EXPLO
(CUSTOMIZED PROJECT EXAMPLE)
< SP EXPL 10 + 10 V EXPLO
+ 20 INTERM EXPLO
(CUSTOMIZED PROJECT EXAMPLE)

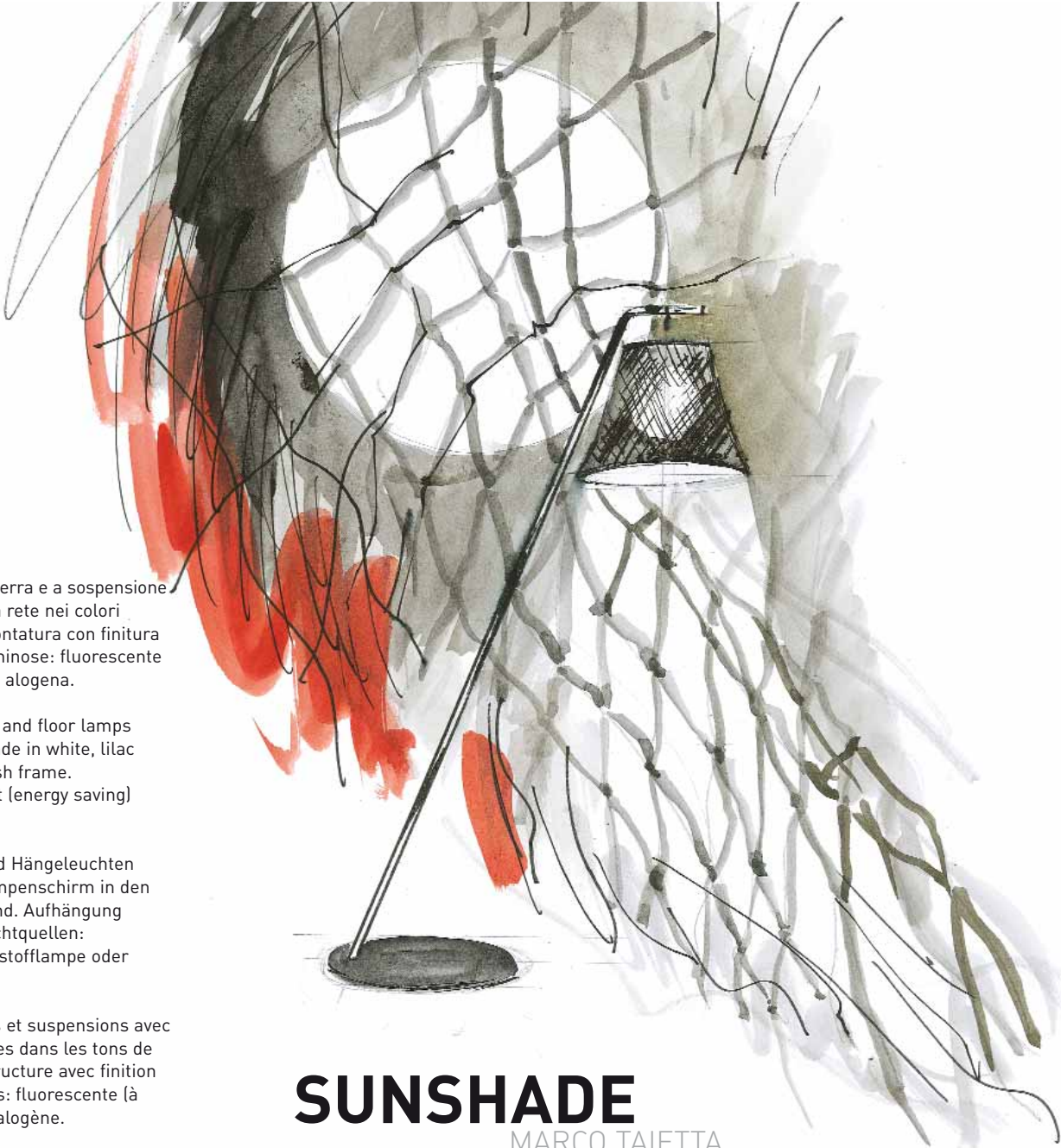

Collezione di lampade da terra e a sospensione con paralume in tessuto a rete nei colori bianco, lilla e sabbia e montatura con finitura grigio alluminio. Fonti luminose: fluorescente (a risparmio energetico) o alogena.

Collection of suspensions and floor lamps with mesh fabric lampshade in white, lilac and sand. Aluminium finish frame. Light sources: fluorescent (energy saving) or halogen.

Kollektion von Boden- und Hängeleuchten mit netzartigem Stoff-Lampenschirm in den Farben Weiß, Lila und Sand. Aufhängung in grauem Aluminium. Lichtquellen: (energiesparende) Leuchtstofflampe oder Halogenlampe.

Collection de lampadaires et suspensions avec abat-jour en tissu à mailles dans les tons de blanc, lilas ou sable et structure avec finition gris aluminium. Ampoules: fluorescente (à économie d'énergie) ou halogène.

Colección de lámparas de pie y de suspensión con pantalla en tejido reticular de color blanco, lila o arena y estructura con acabado gris aluminio. Fuentes luminosas: fluorescente (de ahorro energético) o halógena.

Coleção de luminárias de chão e pendentes com a base em tecido em tela, nas cores branco, lilás e areia, com armação em acabamento cinza alumínio. Fontes luminosas: fluorescente (com economia de energia) ou halógena.

Коллекция напольных и подвесных светильников с абажуром из сетчатой ткани белого, фиолетового и песочного цветов с каркасом из алюминия серого цвета. Люминесцентная (энергосберегающая) или галогенная лампа.

SUNSHADE

MARCO TAIETTA





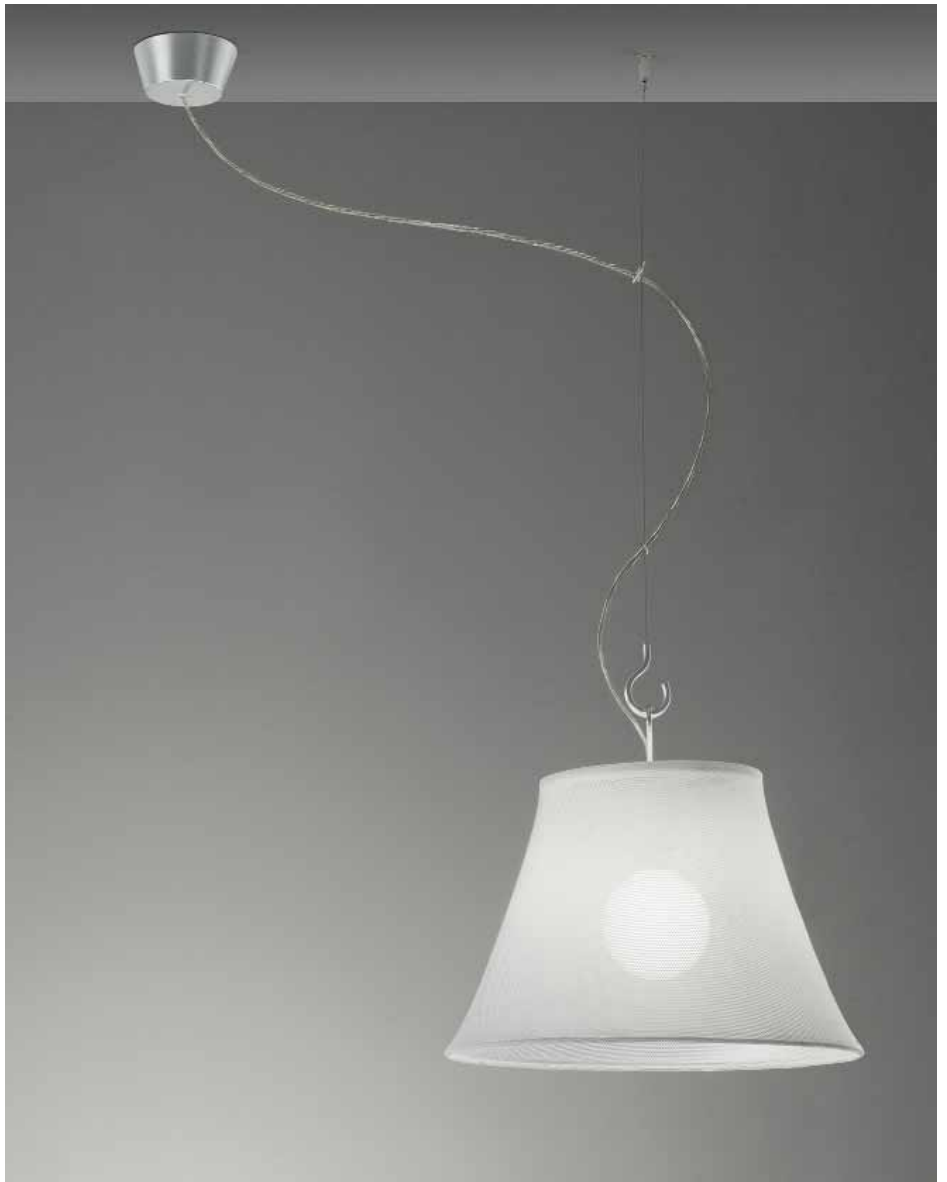

^ SP SUN DE 1
< PT SUNSHA
« PG 74-75: SP SUNSH 1 (DETAIL)



^ PT SUNSHA
> SP SUNSH 1



Collezione di lampade con montatura cromata e paralume lavorato a mano con fili setati. Disponibile in tre colori: bianco avorio, tabacco e nero. Diffusore in metacrilato opalino.

Collection of lamps with chrome frame and hand-made silken thread lampshade. Available in three colours: ivory white, tobacco or black. Opaline methacrylate diffuser.

Leuchtenkollektion mit verchromter Aufhängung und handgefertigtem Lampenschirm mit seidigen Fäden. In drei Farben erhältlich: Elfenbeinweiß, Tabakfarben oder Schwarz. Diffusor aus opalfarbenem Plexiglas.

Collection de lampes avec structure chromée et abat-jour fabriqué à la main avec des fils de soie. Disponible en trois couleurs: blanc d'ivoire, tabac et noir. Diffuseur en méthacrylate opalin.

Colección de lámparas con estructura cromada y pantalla hecha a mano con hilos en seda. Disponible en tres colores: blanco marfil, tabaco y negro. Difusor de metacrilato opalino.

Coleção de luminárias com armação cromada e base trabalhada a mão com fios de seda. Disponível em três cores: branco marfim, tabaco e preto. Difusor em metacrilato opalino.

Коллекция светильников с хромированным креплением и абажуром из шелковых нитей ручной работы. Предлагается в трех цветовых вариантах: белый цвет оттенка «слоновая кость», табачный и черный. Диффузор из матового метакрилата.

CLAVIUS

MANUEL VIVIAN



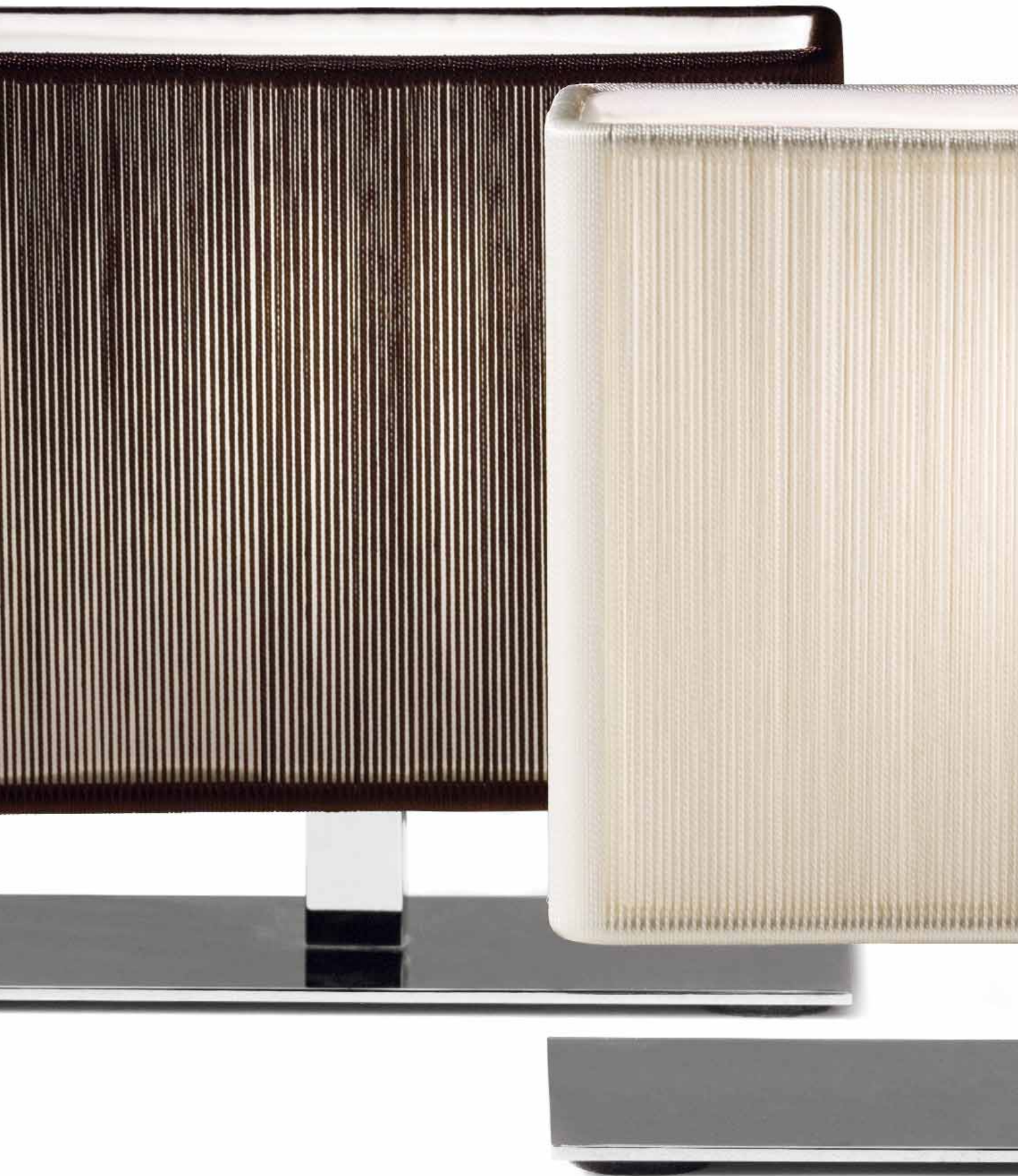





^ PL CLAVIU / AP CLAV PI
< FA CLAVIU
« SP CLAVIU / PT CLAVIU
« PG 80-81: LT CLAV XP



^ SP CLAV 60
> LT CLAVI P / AP CLAV GR



< SP CLAVI P
> SP CL 60 40







- > AP CLAV 30
- SP CLAVIU
- < AP CLAV 45
- LT CLAV XP



- ^ LT CLAVI G
- LT CLAVI P
- LT CLAV XP
- > AP CLAV BR

Collezione di lampade da soffitto e da parete in tessuto elastico sfoderabile e lavabile. Disponibile in bianco, fantasia bianco e fantasia avorio.

Collection of ceiling and wall lamps with removable and washable stretch fabric covers. Available in plain white or pattern in white or ivory.

Decken- und Wandleuchten-Kollektion mit elastischem, abziehbarem und waschbarem Stoff. Erhältlich in Weiß, Weiß gemustert und Elfenbeinfarben gemustert.

Collection de plafonniers et d'appliques en tissu élastique amovible et lavable. Disponible en blanc, blanc fantaisie et ivoire fantaisie.

Colección de lámparas de techo y de pared en tejido elástico desenfundable y lavable. Disponible en blanco, fantasía blanco y fantasía marfil.

Coleção de luminárias de teto e de parede com tecido elástico removível e lavável. Disponível em branco, fantasia branco e fantasia marfim.

Коллекция потолочных и настенных светильников со съёмным абажуром из эластичной моющейся ткани. Предлагается в трех цветовых вариантах: белый, белый с узором и цвета слоновой кости с узором.

NELLY NELLY STRAIGHT

MANUEL VIVIAN

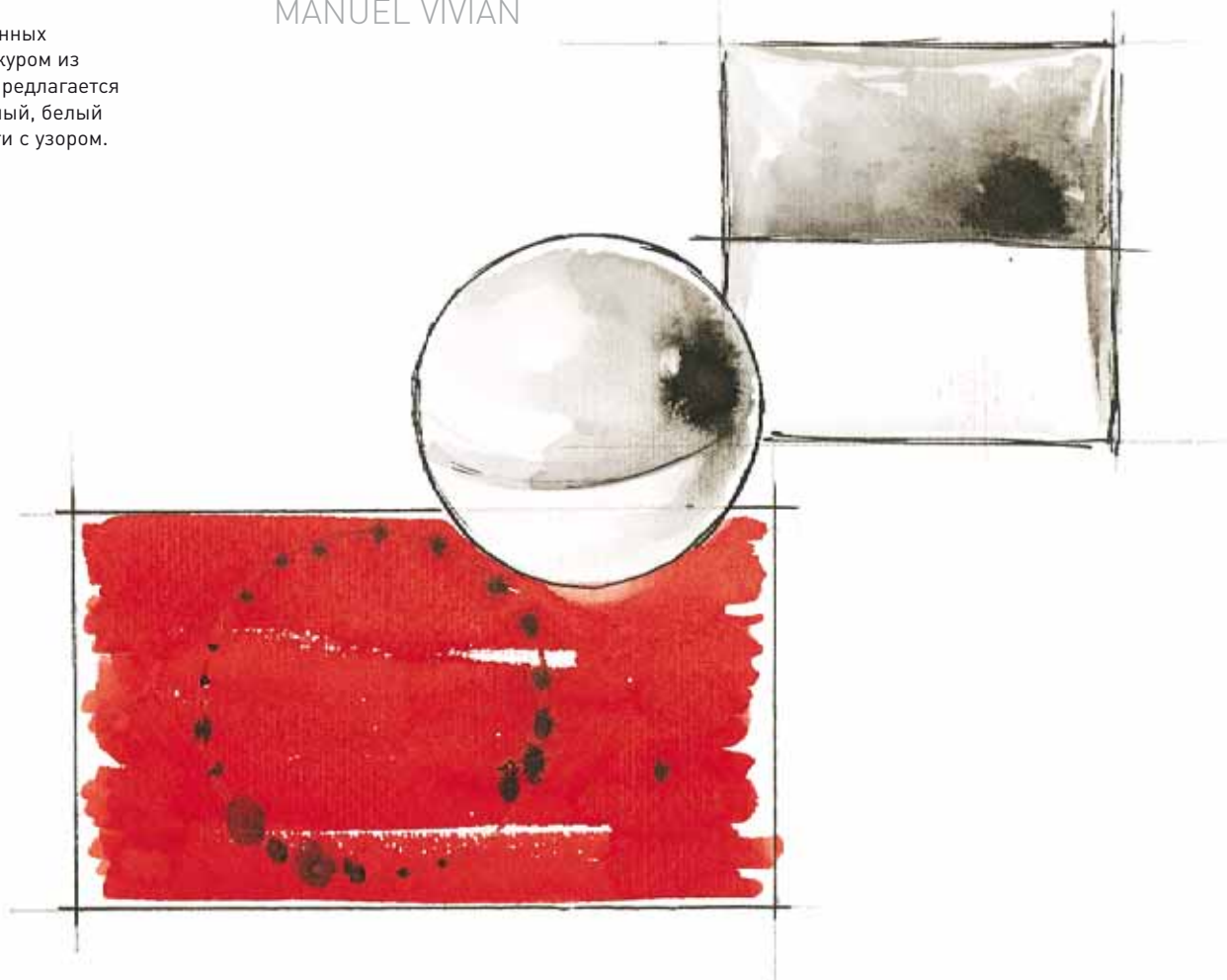





> PL NEL S 60 / PL NE S 100
< PL NEL S 60 / PL NE S 100
« PG 88-89: PL NEL S 60 / PL NE S 100
PL NE S 140 (DETAIL)



^ PL NEL S 60 WHITE DETAIL
PL NEL S 60 IVORY PATTERN DETAIL
PL NEL S 60 WHITE PATTERN DETAIL





^ PL NEL S 60 / PL NE S 100 / PL NE S 140
< PL NELL 60 / PL NEL 100 / PL NEL 140



Collezione Aura con pendenti in vetro colorato incamiciato cristallo e ritorti a mano. Montatura in acciaio lucidato o foglia oro. Colori vetri: bianco, rosso, nero, arancio, tè e cristallo "rigadin".

Aura collection with hand twisted double-layered coloured glass pendants. Frame in polished steel or gold leaf. Glass available in white, red, black, orange, tea and ribbed "rigadin" crystal.

Kollektion Aura mit farbigen und kristallumhüllten Glaspendeln, die von Hand gefertigt werden. Baldachin in poliertem Stahl oder Blattgold. Erhältliche Glasfarben: Weiß, Rot, Schwarz, Orange, Teefarben und Kristall mit Rigadin-Reliefstreifen.

Collection Aura avec des pendeloques en verre coloré chemisé cristal et formés à la main. Structure acier chromé ou doré à la feuille d'or. Couleurs verreries : blanc, rouge, orange, noir, thé et cristal avec "rigadin" relief.

Collección Aura con lagrimas en vidrio de color encamisado con cristal y formado manualmente. Acabado estructura en acero pulido o lámina de oro. Color del vidrio: blanco, rojo, negro, naranja, té y cristal "rigadin".

Coleção Aura com pendentes de vidro colorido, coberto por cristal e retorcidos a mão. Armação em aço polido ou folha de ouro. Cores dos vidros: branco, vermelho, preto, laranja, chá e cristal "rigadin".

Коллекция Aura представляет собой скрученные вручную двухслойные подвески из хрусталя. Потолочное основание светильника изготавливается из полированной стали или из сусального золота. Коллекция предлагается в следующих вариантах: белый, красный, чёрный, оранжевый, чайный и ребристый хрусталь "rigadin".

AURA

MANUEL VIVIAN







< SP AURA 60
COLOURS: RED / ORANGE / BLACK
TEA / WHITE / CRYSTAL
« PG 94-95: SP AU 60/3 (DETAIL)



^ FA AURA 44
> SP AU 60/2







^ PL AUR G 30
< AURA GLASS DETAIL
« AP AURA / PL AURA GR

Collezione completa di lampade in metallo
con finitura cromo con regolazione direzionale
del fascio luminoso.

Complete collection of lamps in chrome
finish metal. Adjustable light beam.

Komplette Leuchtenkollektion aus
verchromtem Metall mit ausrichtbarem
Lichtstrahl.

Collection complète de lampes en métal
finition chrome avec réglage directionnel
du faisceau lumineux.

Colección completa de lámparas de metal
con acabado cromado y regulación
direccional del haz luminoso.

Coleção completa de luminárias de metal
com acabamento cromo e regulação
direccional do feixe luminoso

Коллекция светильников из хромированного
металла с регулированием направления
светового потока.

AX20

MANUEL VIVIAN









- ^ AP AX20 PI / SP AX20 PI
- < AP AX20 PI
- « PT AX20
- « PG 103: PT AX20 / LT AX20





^ AP AX20 PI / LT AX20
< AP AX20 GR

Collezione completa di lampade disponibili in bianco o tabacco in cui il paralume e il rosone sono costituiti da fettucce setate. L'interno del paralume è in tessuto bianco.

Collection of lamps available in white or tobacco. Silken ribbon lampshades and canopies. Inner part of the lampshades in white fabric.

Komplette Leuchtenkollektion in den Farben Weiß und Tabak mit Lampenschirm und Baldachin aus seidenen Bändern. Die Innenseite des Lampenschirms besteht aus weißem Stoff.

Collection complète de lampes disponibles en blanc ou tabac avec abat-jour et rosace constitués de rubans en soie, intérieur en tissu blanc.

Colección completa de lámparas disponibles en blanco o tabaco. Pantalla y florón formados por cintas de seda. El interior de la pantalla es de tela blanca.

Coleção completa de luminárias disponíveis em branco ou tabaco, onde a base é constituída de fitas de seda. O interior da base é de tecido branco.

Полная коллекция светильников белого или табачного цвета с абажуром и розеткой, состоящими из шелковых полос. Внутренняя сторона абажура выполнена из белой ткани.

OBI

MANUEL VIVIAN









^ AP OBI / SP OBI 43
< PT OBI
« LT OBI
« PG 108-109: LT OBI (DETAIL)



- ^ SP OBI 63 (DETAIL)
- > SP OBI 63
- » LT OBI / SP OBI 20



Collezione di lampade da parete in metallo verniciato bianco texturizzato o bianco con frontalino grigio basalto oppure con finitura effetto cor-ten. Disponibili in due misure e con lampadina alogena lineare.

Collection of metal wall lamps available in: textured white, white with basalt grey front cover or with cor-ten finish. Available in two sizes and with linear halogen light source.

Wandleuchtenkollektion aus texturiertem weiß lackiertem Metall, oder weiß mit basaltgrauer Frontblende oder mit Corten-Finish. In zwei Größen erhältlich, mit linearer Halogenlampe.

Collection d'appliques en métal laqué blanc texturé ou blanc avec platine finition gris basalte ou finition effet cor-ten. Disponibles en deux dimensions, avec ampoule halogène linéaire.

Colección de lámparas de pared en metal pintado blanco texturizado o blanco con frontal gris basalto o con acabado efecto cor-ten. Disponibles en dos dimensiones y con bombilla halógena lineal.

Coleção de luminárias de parede em metal envernizado branco texturizado ou branco com frente cinza basalto ou com acabamento efeito cor-ten. Disponíveis em duas medidas e com lâmpada halógena linear.

Коллекция настенных светильников из металла, окрашенного белой текстурной краской или с отделкой, имитирующей эффект ржавчины. Предлагаются два размера, в том числе с галогенной линейной лампой.

POLIA

MANUEL VIVIAN









^ AP POLIA P / AP POLIA G
< AP POLIA G
« PG 114-115: AP POLIA P (DETAIL)



^ AP POLIA P
> AP POLIA P



Lampada da parete disponibile in metallo verniciato bianco texturizzato o in acciaio lucido. Sorgente luminosa alogena.

Wall light available in textured white painted metal or in polished steel. Halogen light source.

Wandleuchte erhältlich in texturiertem, weiß lackiertem Metall, oder in glänzendem Stahl. Mit Halogenlampe.

Applique disponible en métal laqué blanc texturé ou en acier chromé. Ampoule halogène.

Lâmpara de pared disponible en metal pintado blanco texturizado o en acero pulido. Fuente luminosa halógena.

Luminária de parede disponível em metal envernizado branco texturizado ou de aço polido. Fonte luminosa halógena.

Настенный светильник из металла, окрашенного белой текстурной краской, или из блестящей стали. Галогенная лампа.

VASILY

MANUEL VIVIAN



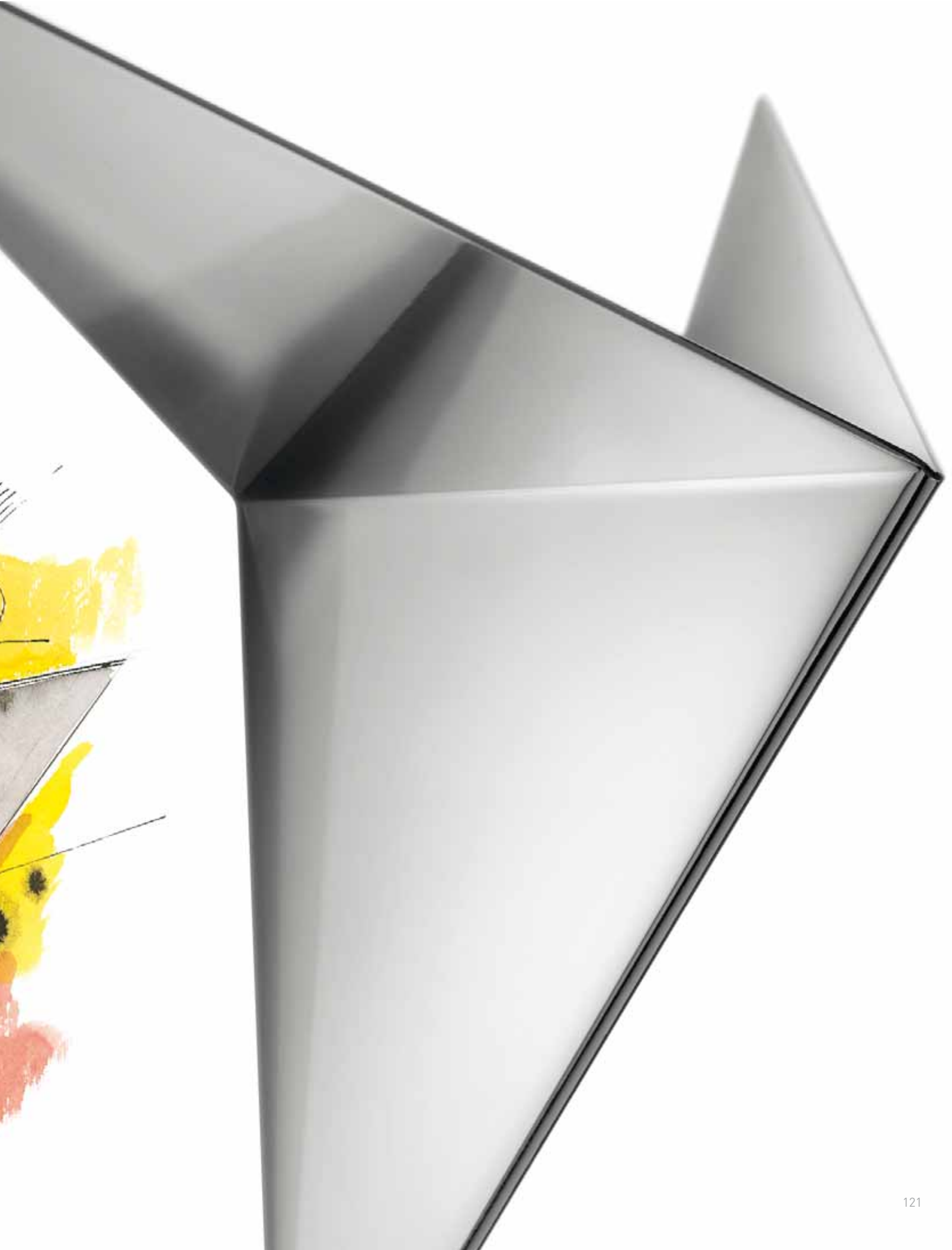



- > AP VASILY
- < AP VASILY
- « PG 120-121: AP VASILY (DETAIL)
- √ AP VASILY WITH BACKPLATE

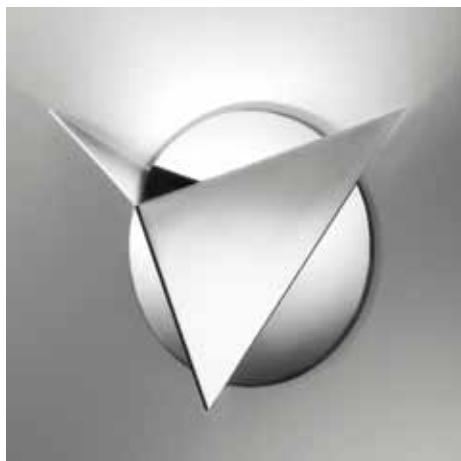

Collezione di lampade da parete in metallo incurvato e verniciato nei colori bianco perla, bronzo o finitura cromo. Disponibili in due misure e con lampadina alogena lineare.

Collection of wall lights in curved metal, painted in pearl white and bronze colours or available with chrome finish. Two sizes and linear halogen light source.

Wandleuchtenkollektion aus gebogenem Metall, lackiert in den Farben Perlweiß, Bronze oder mit Chrom-Finish. In zwei Größen erhältlich, mit linearer Halogenlampe.

Collection d'appliques en métal courbé et laqué dans les tons de blanc perle, bronze ou finition chromée. Disponibles en deux dimensions, avec ampoule halogène linéaire.

Colección de lámparas de pared en metal curvado y pintado en los colores blanco perla, bronzo o acabado cromo. Disponibles en dos medidas y con bombilla halógena lineal.

Coleção de luminárias de parede em metal curvado e envernizado nas cores branca pérola, bronze ou acabamento cromo. Disponíveis em duas medidas e com lâmpada halógena linear.

Коллекция настенных ламп из изогнутого металла, окрашенных в следующие цвета: белый жемчуг, бронза или хромированная отделка. Предлагается в двух размерах с галогенной линейной лампой.

URIEL

MANUEL VIVIAN







- > AP URIEL G (DETAIL)
- < AP URIEL G
- « PG 125: AP URIEL P (DETAIL)
- √ AP URIEL P



Collezione di appliques con montatura in metallo, paralume in ceramica di colore nero o bianco. Sorgente luminosa alogena o LED (attacco GU10).

Collection of wall lamps with metal frame and black or white ceramic lampshade. Halogen or LED light source (GU10 fitting).

Wandleuchten-Kollektion mit Aufhängung aus Metall und weißem oder schwarzem Keramiklampenschirm. Mit Halogen- oder LED-Lampe (GU10-Fassung).

Collection d'appliques avec monture en métal, abat-jour en céramique de couleur noire ou blanche. Ampoule halogène ou LED (culot GU10).

Colección de apliques con estructura en metal, pantalla en cerámica de color negro o blanco. Fuente luminosa halógena o LED (pitón GU10).

Coleção de arandelas com armação de metal, base em cerâmica nas cores preto ou branco. Fonte luminosa halógena ou LED (acoplamento GU10).

Коллекция бра с металлическим каркасом и абажуром из керамики черного или белого цвета. Источник света: галогенная лампа или светодиод (цоколь GU10).

SHARAV

CAMBI-SCATENA-TURINI

AP SHARAV





Collezione in vetro soffiato con parti in metallo cromato. Disponibile nelle versioni con vetro trasparente o cromato.

Suspensions in blown-glass and chrome finish. Available in clear glass or chrome glass version.

Kollektion aus mundgeblasenem Glas mit verchromten Metallteilen. Erhältlich mit transparentem oder verchromtem Glas.

Collection de lampes en verre soufflé avec parties en métal chromé. Disponible avec verre transparent ou chromé.

Colección en vidrio soplado con partes en metal cromado. Disponible en las versiones de vidrio transparente o cromado.

Coleção de vidro soprado com partes em metal cromado. Disponível nas versões com vidro transparente ou cromado.

Коллекция из дутого стекла с деталями из хромированного металла. В наличии имеются варианты с прозрачным или хромированным стеклом.

BLUM

MARCELLO FURLAN

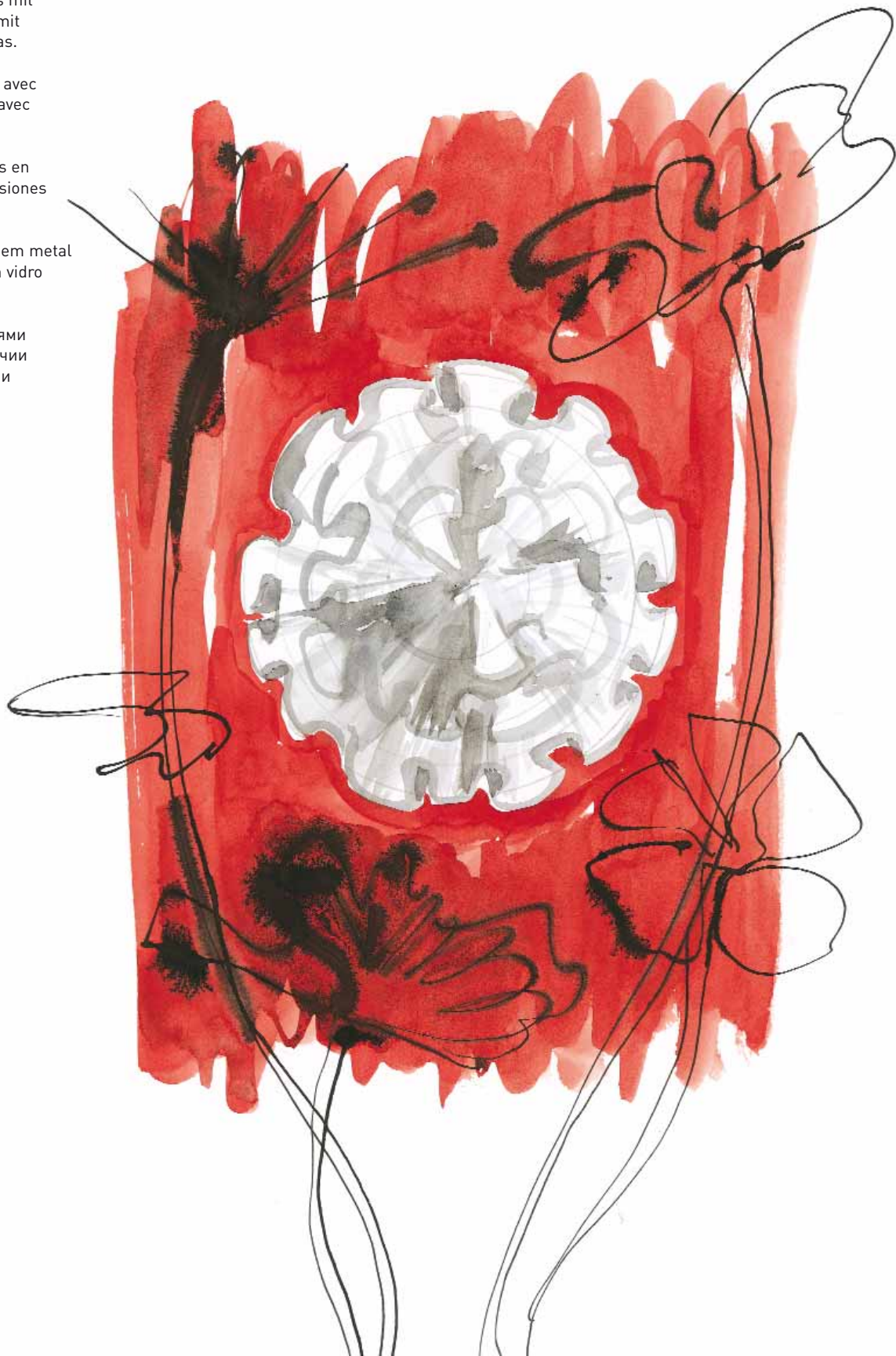





- > SP BLUM 19
- < SP BLUM 31
- « PG 131: SP BLUM 19 (DETAIL)
- √ SP BLUM 1



Collezione di lampade da soffitto e da parete con struttura metallica e rivestimento in tessuto elasticizzato bianco o avorio, sfoderabile e lavabile. Misure disponibili 100x100 cm e 60x60 cm.

Collection of ceiling and wall lamps with metal frame and with a removable and washable stretch fabric cover. Available in white or ivory and in two sizes: 60x60 cm and 100x100 cm.

Decken- und Wandleuchten-Kollektion mit Aufhängung aus Metall und elastischem, weißem oder elfenbeinfarbenem Stoff, der abgezogen und gewaschen werden kann. Erhältliche Größen: 60x60 cm und 100x100 cm.

Collection de plafonniers et d'appliques avec structure métallique et revêtement en tissu élastique blanc ou ivoire, amovible et lavable. Dimensions disponibles: 100x100 cm et 60x60 cm.

Colección de lámparas de techo y de pared con estructura metálica y revestimiento en tejido blanco o marfil elasticado, desenfundable y lavable. Medidas disponibles: 100x100 cm y 60x60 cm.

Coleção de luminárias de teto e parede com estrutura metálica e revestimento em tecido elástico branco ou marfim, removível e lavável. Medidas disponíveis 100x100 cm e 60x60 cm

Коллекция потолочных и настенных светильников с металлическим каркасом и съемным абажуром из эластичной моющейся ткани белого цвета или цвета слоновой кости. Предлагаемые размеры: 100x100 см и 60x60 см.

STORMY

MANUEL VIVIAN



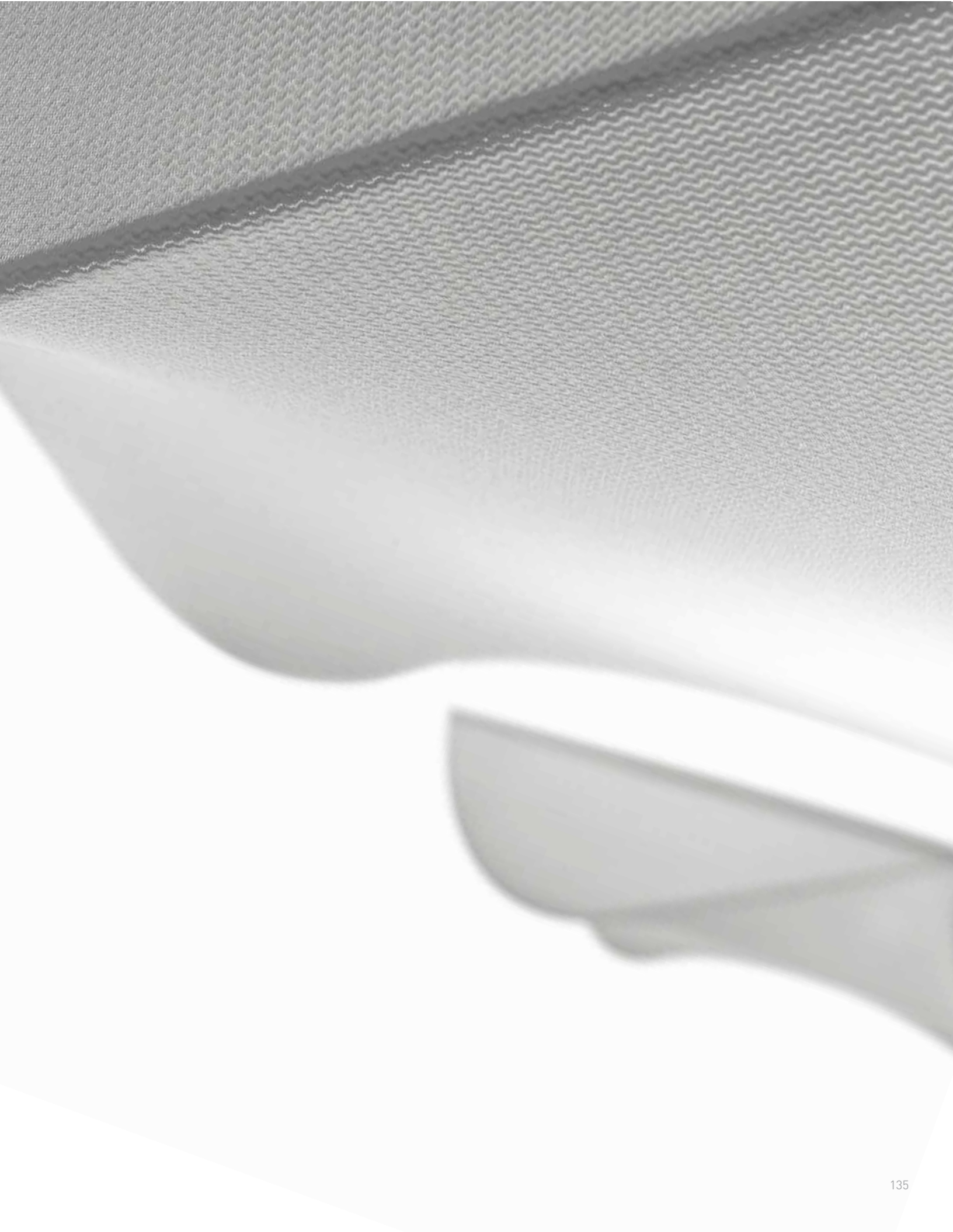



> PL STOR 60 / PL STO 100
< PL STOR 60 / PL STO 100
« PG 134-135: PL STOR 60
PL STO 100 (DETAIL)



^ PL STOR 60 IVORY DETAIL
> PL STOR 60 WHITE DETAIL

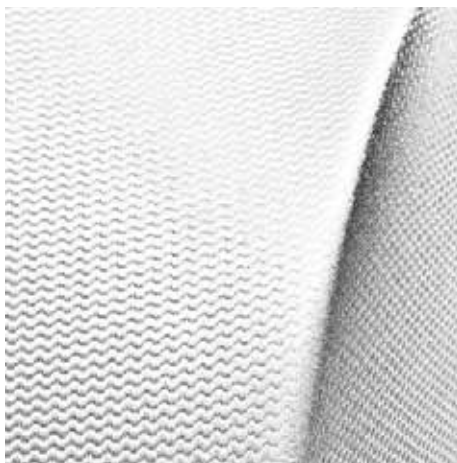



Collezione con pendenti in cristallo e parti in nichel satinato. Disponibile nei colori cristallo o nero.

Collection with crystal pendants and satin-finish nickel parts. Available in clear colour or black.

Kollektion mit Kristall-Pendeln und Elementen aus satiniertem Nickel. Erhältlich in den Farben Kristall oder Schwarz.

Collection avec pendoques en cristal et parties en nickel satiné. Disponible en cristal ou noir.

Colección con colgantes en cristal y partes en níquel satinado. Disponible en color cristal o negro.

Coleção de luminárias de teto e parede com estrutura metálica e revestimento em tecido elástico branco ou marfim, removível e lavável. Medidas disponíveis 100x100 cm e 60x60 cm.

Коллекция с подвесками из хрустала и матовыми никелированными деталями. Лампы предлагаются в прозрачном и чёрном варианте.

MARYLIN

MANUEL VIVIAN

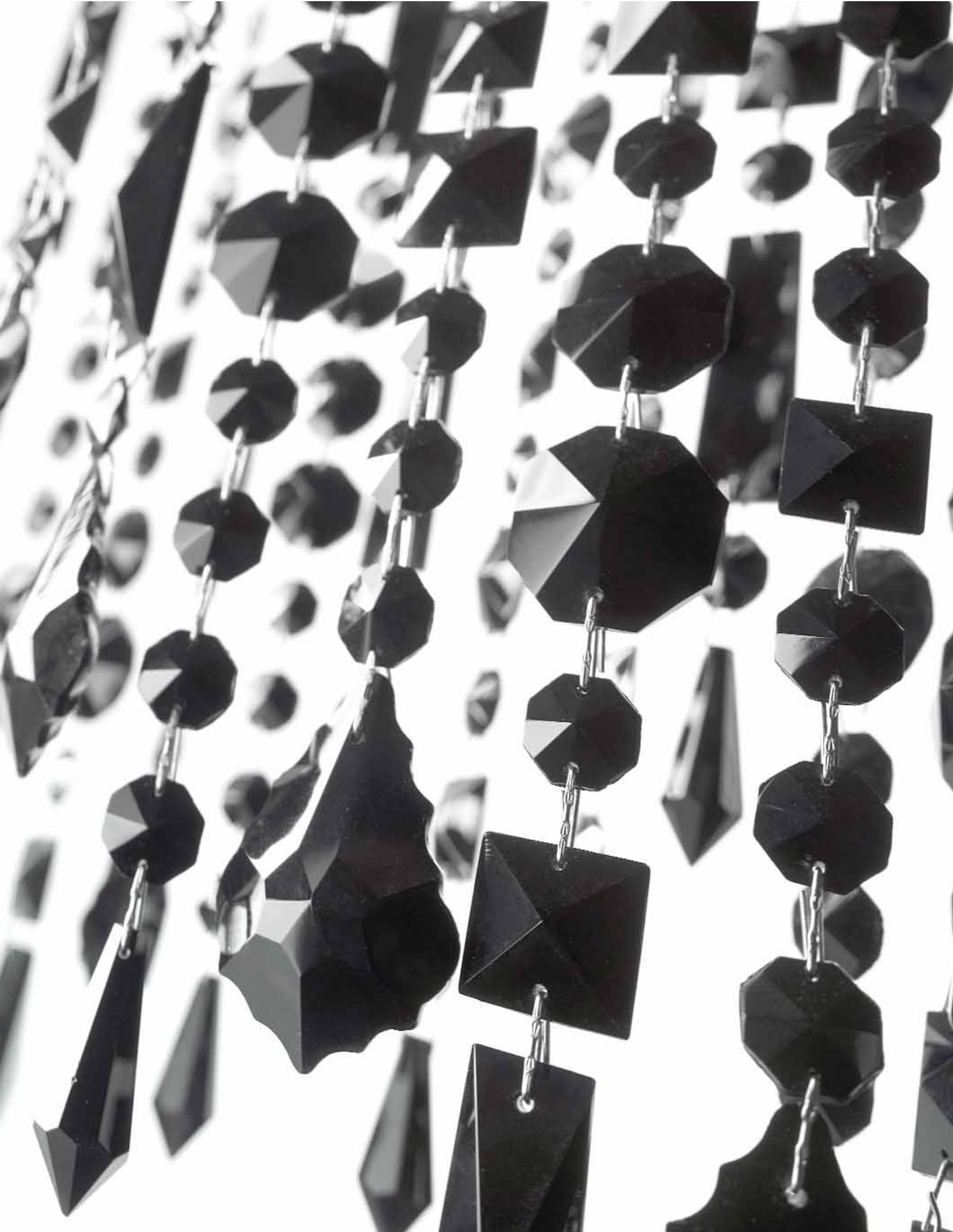







^ AP MARYLI / SP MAR 100
^ SP MARYLI
< SP MARY 36
« PG 138-139: SP MARY 36 (DETAIL)

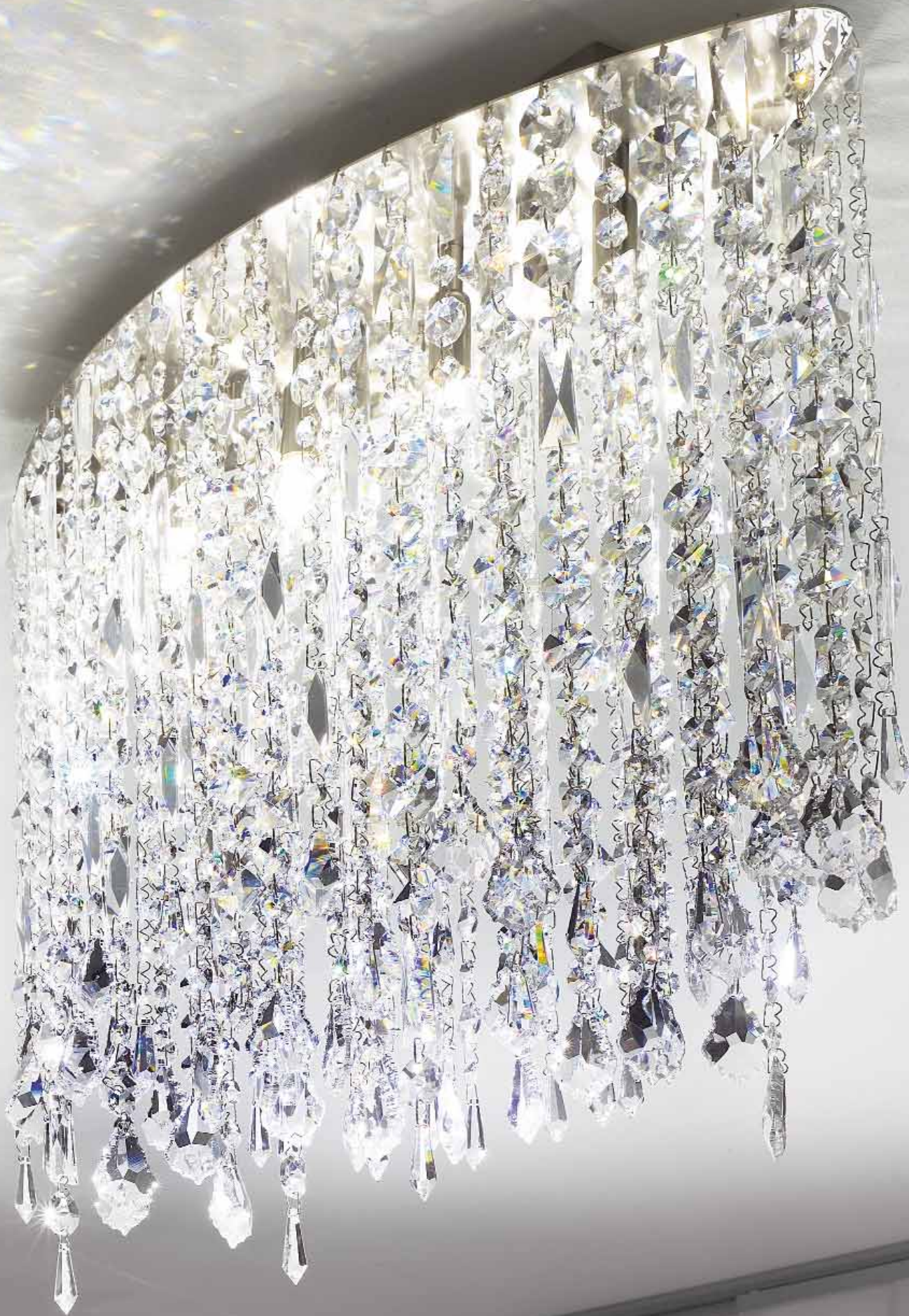

- ^ FA MARYLI
- < SP MARYL P / PT MARYLI
- > PL MARY 66





Collezione di lampade da parete e da soffitto in tessuto ignifugo, sfoderabile, lavabile, e elastico retato a due strati. Disponibile in tre tonalità: fondo bianco e rete bianca, fondo arancio e rete nera, fondo bianco e rete nera.

Collection of wall and ceiling lamps made with a double-layer fireproof, removable and washable stretch net fabric. Available in three versions: white background with white net, orange background with black net, white background with black net.

Wand- und Deckenleuchten-Kollektion mit elastischem, feuerhemmendem Netzstoff, bestehend aus zwei Stofflagen, abziehbar und waschbar. In drei Farbtönen erhältlich: Grundstoff weiß mit weißem Netz, Grundstoff orange mit schwarzem Netz, Grundstoff weiß mit schwarzem Netz.

Collection d'appliques et de plafonniers en tissu technique élastique ignifugé, amovible, lavable et réticulé à deux couches. Disponible en trois couleurs: fond blanc et résille blanche, fond orange et résille noire, fond blanc et résille noire.

Colección de lámparas de pared y de techo en tejido ignífugo, desfundable, lavable y elástico con retículo de dos capas. Disponible en tres tonalidades: fondo blanco y malla blanca, fondo anaranjado y malla negra, fondo blanco y malla negra.

Coleção de luminárias de parede e de teto em tecido à prova de fogo, removível, lavável e elástico com tela de duas camadas. Disponível em três tonalidades: fundo branco e tela branca, fundo laranja e tela preta, fundo branco e tela preta.

Коллекция настенных и потолочных светильников из огнестойкой эластичной сетчатой двухслойной ткани. Предлагается выбор из трех расцветок: белый фон и белая сетка, оранжевый фон и чёрная сетка, белый фон и чёрная сетка.

UKIYO

MANUEL VIVIAN



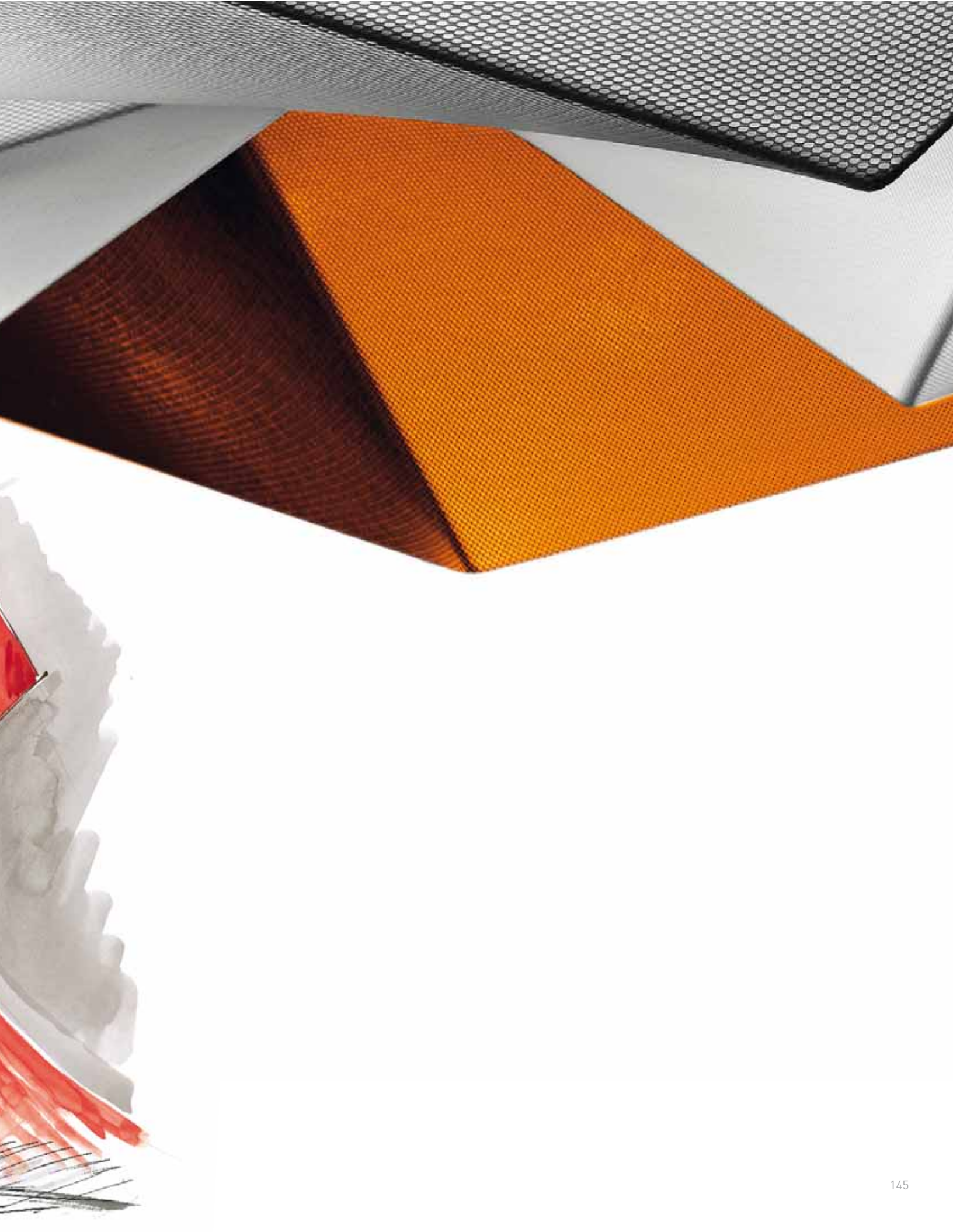



> PL UKI 110 / PL UKIYO P
< PL UKIYO G / PL UKIYO P
« PG 144-145: PL UKIYO G / PL UKIYO P
(DETAIL)



^ PL UKI 110 (DETAIL)
> PL UKIYO P (DETAIL)

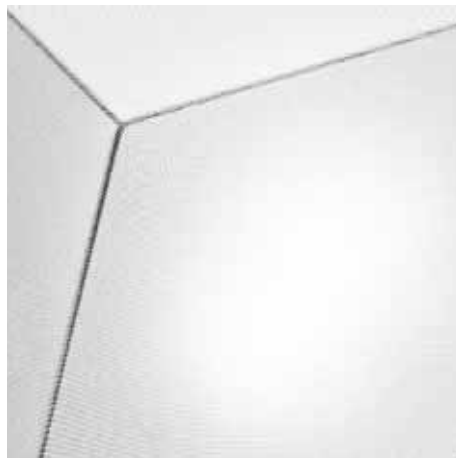

Collezione di lampade con paralume in legno di bambù finitura wengé scuro e diffusori in vetro soffiato bianco satinato. Finiture cromate.

Collection of lamps with dark wengé - finish bamboo lampshade and white satin-finish blown glass diffusers. Chrome finishes.

Leuchtenkollektion mit Lampenschirm aus Bambusholz, Ausführung Wenge dunkel, und Diffusoren aus mundgeblasenem, weiß satiniertem Glas. Metallteile verchromt.

Collection de lampes avec abat-jour en bois de bambou, finition wengé foncé et diffuseurs en verre soufflé blanc satiné. Finitions chromées.

Colección de lámparas con pantalla en madera de bambú, acabado wengé oscuro y difusores en vidrio soplado blanco satinado. Acabados cromados.

Coleção de luminárias com a base madeira de bambu wengé escuro e difusores em vidro soprado branco acetinado. Acabamentos cromados.

Коллекция ламп с абажуром из бамбука с отделкой темного цвета венге и рассеивателями из дутого матового белого стекла. Хромированная отделка.

KOSHI

MANUEL VIVIAN









- ^ LT KOSHI G / SP KOSHI G
- < PL KOSHI
- « SP KOSHI M
- « PG 149: SP KOSHI M (DETAIL)

Collezione di lampade a sospensione in vetro soffiato bianco acidato e montatura in metallo verniciato bianco. Disponibile in due dimensioni: Ø 35 e Ø 50 cm. Fonte luminosa fluorescente o alogena con attacco E27.

Collection of suspensions in white acid-treated blown glass with a white painted metal frame. Available in two sizes: Ø 35 and Ø 50 cm. Fluorescent or halogen light source with E27 fitting.

Hängeleuchten-Kollektion aus weiß geätztem, mundgeblasenem Glas mit weiß lackierter Aufhängung aus Metall. In zwei Größen erhältlich: Ø 35 und Ø 50 cm. Leuchtquelle Halogen - oder Leuchtstofflampe mit E27 Fassung.

Collection de suspensions en verre soufflé blanc poli à l'acide et monture en métal laqué blanc. Disponible en deux dimensions : Ø 35 et Ø 50 cm. Ampoule fluorescente ou halogène avec culot E27.

Colección de lámparas de suspensión en vidrio soplado blanco acidado y estructura en metal pintado blanco. Disponible en dos tamaños: Ø 35 y Ø 50 cm. Fuente luminosa fluorescente o halógena con portalámparas E27.

Coleção de luminárias pendentes em vidro soprado opaco branco e armação de metal envernizado branco. Disponível em dois tamanhos: Ø 35 e Ø 50 cm. Fonte luminosa fluorescente ou halógena com ligação E27.

Коллекция подвесных светильников из белого травленого дутого стекла с металлическим каркасом, окрашенным в белый цвет. Светильники предлагаются двух размеров: r 35 и r 50 см. Люминесцентная или галогенная лампа с цоколем E27.



KUDLIK

MANUEL VIVIAN



Collezione completa di lampade in cristallo e montatura con finitura in metallo cromato. I paralumi montati su alcuni articoli sono disponibili nei colori: cromo con interno cromo satinato, rosso con interno bianco, vaniglia con interno oro, bianco con interno bianco. Le plafoniere sono dotate di lastra di copertura in vetro nero bisellato.

Complete collection of crystal lamps with chrome finish metal frame. The lampshades for specific items are available in the following colours: chrome exterior with satin - finish chrome interior, red exterior with white interior, vanilla exterior with gold interior, white exterior with white interior. Ceiling lamps are equipped with a black beveled glass covering plate.

Komplette Leuchtenkollektion aus Kristall mit verchromter Aufhängung. Die auf einigen Modellen montierten Lampenschirme sind in folgenden Farben erhältlich: Chrom und innen Seidenmatt verchromt, Rot und innen Weiß, Vanillefarben und innen Goldfarben, Weiß und innen Weiß. Die Abdeckung der Deckenleuchten besteht aus einer an den Kanten abgeschrägten, schwarzen Glasplatte.

Collection complète de lampes en cristal et structure avec finition en métal chromé. Les abat-jours sont disponibles dans les couleurs suivantes: chrome avec intérieur chrome satiné, rouge avec intérieur blanc, vanille avec intérieur doré et blanc avec intérieur blanc. Les plafonniers sont équipés d'une plaque couvrante en verre noir poli.

Colección completa de lámparas en cristal y estructura con acabado en metal cromado. Las pantallas montadas en algunos artículos se encuentran disponibles en los colores cromo con interno en cromo satinado, rojo con interno blanco, vainilla con interno oro y blanco con interno blanco. Los plafones disponen de una placa de cobertura en vidrio biselado negro.

Coleção completa de luminárias de cristal e armação com acabamento de metal cromado. A base montada em alguns artigos estão disponíveis nas cores: cromo com interior cromo acetinado, vermelho com interior branco, baunilha com interior ouro, branco com interior branco. As arandelas são feitas com chapa de cobertura em vidro preto chanfrado.

Полная коллекция ламп из хрустала с оправой из хромированного металла. Абажур, монтируемый на некоторые изделия, предлагается в следующей цветовой гамме: хром снаружи и матовый хром внутри, красный снаружи и белый внутри, цвет ванили снаружи и золотой внутри, белый снаружи и внутри. Плафоны оснащаются пластиной из черного фацетированного стекла.



SUBZERO
MANUEL VIVIAN







^ LT SUBZER
< LT SUBZER
<< PG 155: SP SUBZ 20 (DETAIL)



- ^ SP SUBZ 20
- > SP SUBZ 10
- » SP SUBZ 50







- > 3 x SP SUBZ DE (DETAIL)
- « PL SUBZ 16 / AP SUBZER
- ∨ FA SUBZ 15



- ^ AP SUBZER
- > FA SUBZER

Collezione di lampade da parete, da tavolo e sospensione in acciaio lucido e metacrilato, con paralumi in tessuto disponibili nei colori vaniglia o rosso.

Collection of suspension, table and wall lamps in polished steel and methacrylate. Fabric lampshades available in vanilla or red colours.

Wand-, Tisch- und Hängeleuchten-Kollektion aus glänzendem Stahl und Plexiglas. Lampenschirme aus Stoff in den Farben Vanille und Rot.

Collection d'appliques, de lampes de table et suspensions en acier chromé et méthacrylate. Abat-jour en tissu disponible dans les couleurs vanille et rouge.

Colección de lámparas de pared, de mesa y de suspensión en acero pulido y metacrilato, con pantallas de tela disponibles en color vainilla o rojo.

Coleção de luminárias de parede, de mesa e pendentes de aço polido e metacrilado, com base de tecido, disponíveis nas cores baunilha ou vermelha.

Коллекция настенных, настольных и подвесных светильников, выполненных из полированной стали и метакрилата с абажуром из ткани красной или ванильной расцветки.

SLIGHT

MANUEL VIVIAN









^ AP SLIGHT / SP SLIGHT
< LT SLIGHT P
<< PG 162-163: LT SLIGHT G (DETAIL)

Collezione di lampade da parete in vetro
di colore bianco; finiture in metallo cromato.

Glass wall lamp collection available in white.
Chrome metal finishes.

Wandleuchten mit weißen Glaseinsätzen,
Struktur aus verchromten Metall.

Appliques en verre disponible en blanc.
Finitions en métal chromé.

Colección de lámparas de pared en vidrio,
disponibles en color blanco; acabados en
metal cromado.

Coleção de luminárias de parede em vidro,
disponíveis na cor branca; acabamentos
em metal cromado.

Коллекция настенных светильников
из стекла белого цвета с отделкой из
хромированного металла.

BALIOS

MANUEL VIVIAN



AP BALI 25



Handwritten scribbles on the left edge of the page.



Collezione con rose in cristallo trasparenti o rosse e finiture in metallo cromato. Plafoniera, applique e faretto ad incasso in vetro temperato e serigrafato bianco.

Collection with clear or red crystal roses and chrome finish metal. Ceiling, wall lamps and recessed spotlights available in white screen-printed tempered glass.

Kollektion mit Rosendekoration aus transparentem Kristall oder in Rot mit verchromten Metallteilen. Wand- und Deckenleuchten sowie Einbauspots aus gehärtetem Glas und mit weißem Siebdruck.

Collection avec roses en cristal transparent ou rouge et finitions en métal chromé. Plafonnier, applique et spot encastrable en verre trempé et sérigraphié blanc.

Colección con rosas en cristal, transparentes o rojas, y acabados en metal cromado. Plafón, aplique y foco empotrable en vidrio templado y serigrafiado blanco.

Coleção com rosas em cristal transparente ou vermelhas e acabamentos de metal cromado. Arandela e spot de embutir em vidro temperado e serigrafado branco.

Коллекция с розами, выполненными из прозрачного или красного хрустала с отделкой из хромированного металла. Плафон, настенный светильник или встроенный точечный светильник из белого сериграфированного и закаленного стекла.

SHIRAZ

MANUEL VIVIAN



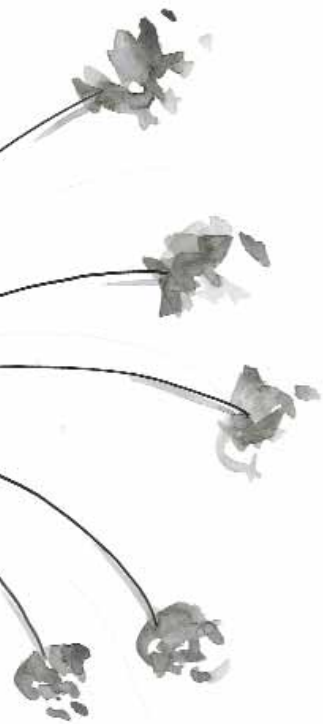

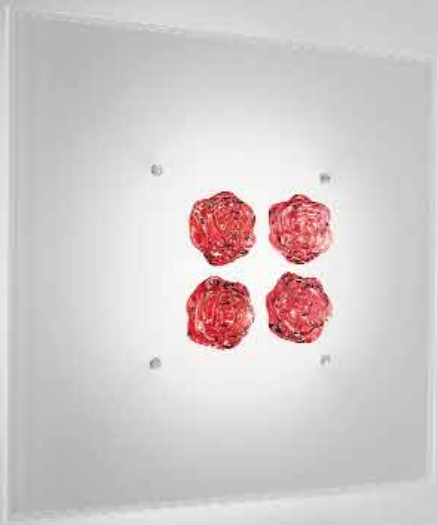

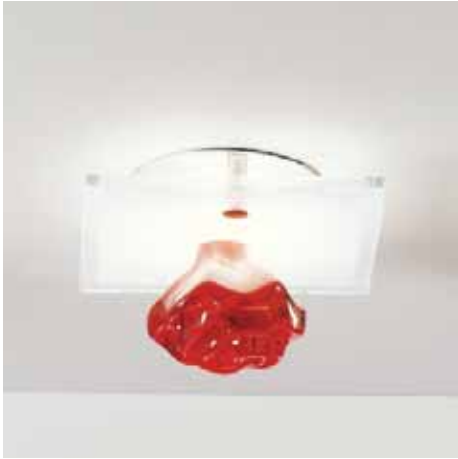

- ^ FA SHIRAZ
- ^ PL SHIRA P
- > PL SHIRA G
- ⌘ PL SHIRA M
- « PG 169: PL SHIRA P (DETAIL)
- FA SHIRAZ

Collezione di faretti (Mencar e Nashira)
in cristallo e finitura in metallo.

Spotlight collection (Mencar and Nashira)
in crystal with metal finish.

Einbauspots (Mencar und Nashira) aus
Kristall mit verchromten Metallteilen.

Spots encastrables (Mencar et Nashira)
en cristal et finition métal.

Colección de focos (Mencar y Nashira)
de cristal con acabados en metal.

Coleção de spots (Mencar e Nashira) de
cristal e acabamento de metal.

Коллекция точечных светильников
(Mencar и Nashira) из хрустала
с металлической отделкой.

CRYSTAL SPOTLIGHT

MANUEL VIVIAN

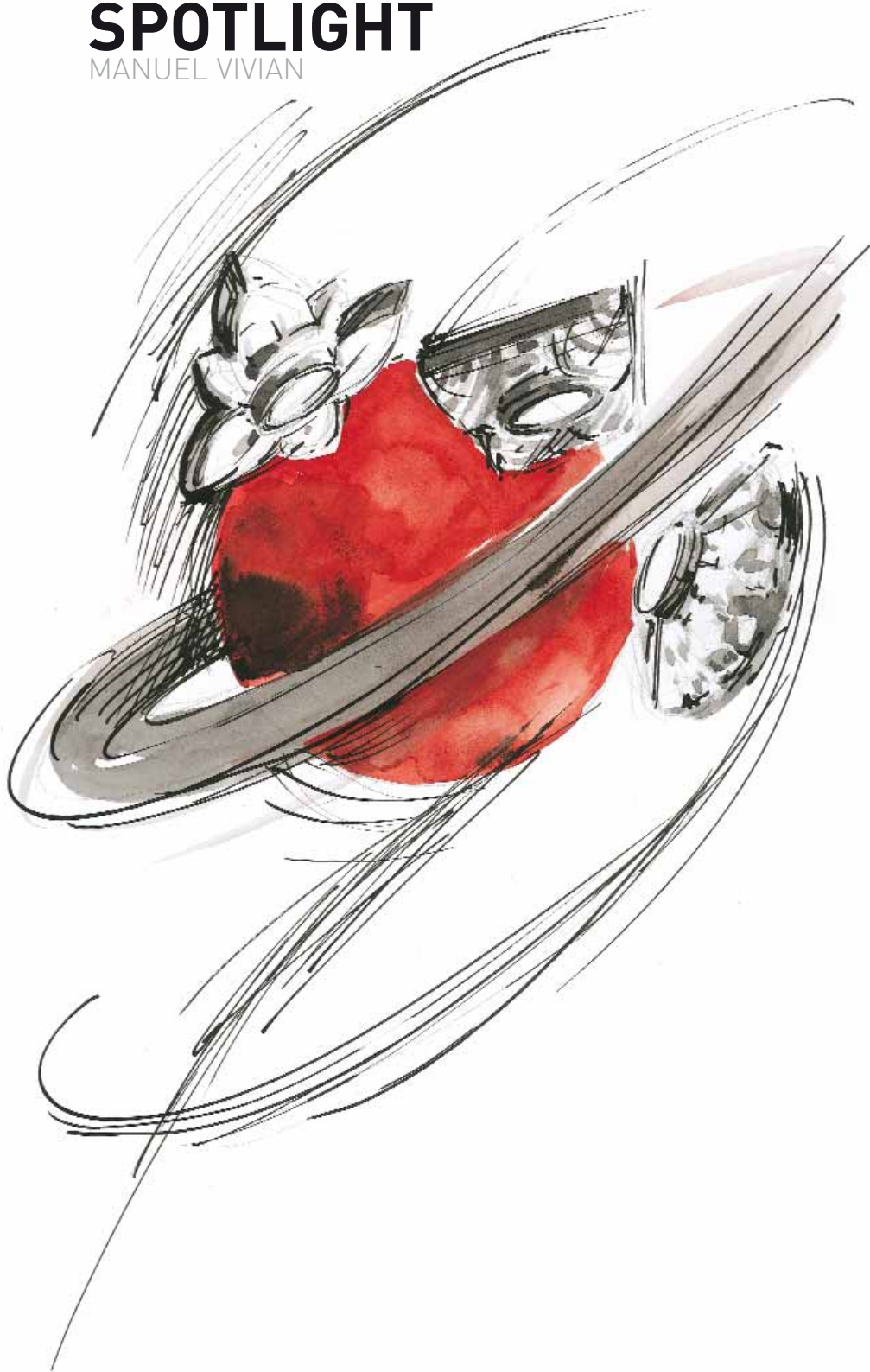

FA MENCAR / FA NASHIRA





TECHNICAL DATA

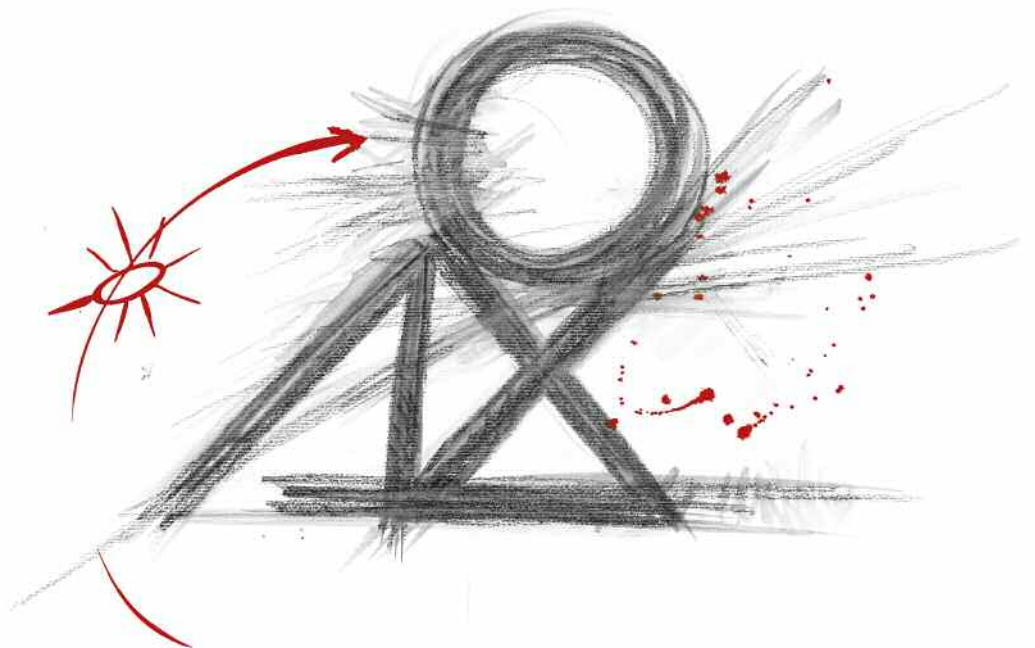

Axo Light si riserva il diritto di apportare ai modelli, senza alcun preavviso, qualsiasi modifica ritenesse opportuna. Axo Light non risponde per eventuali danni a persone o cose causati da una non corretta installazione dei propri apparecchi d'illuminazione. I dati riportati sono puramente indicativi; è possibile che siano riportati degli errori di stampa.

Axo Light reserves itself the right to introduce any changes to its own models, without prior notice. Axo Light is not liable for injuries or damage due to the incorrect installation of its fixtures. The details given here are intended purely as guidance as errors may have occurred during the printing process.

Axo Light behält sich das Recht vor, jederzeit und ohne Voranmeldung, Änderungen der Kollektion vorzunehmen, ohne jedoch die charakteristischen Eigenschaften der Artikel zu ändern. Axo Light ist nicht verantwortlich für eventuelle Personen -oder Sachschäden, verursacht durch unsachgemäße Installation der Produkte. Aufgrund möglicher Druckfehler, sind die angegebenen Daten lediglich als Richtwerte zu verstehen.

Axo Light se réserve le droit de modifier ses collections à tous moments et sans préavis, dans le respect des caractéristiques de base du produit. Axo Light ne répond pas aux éventuels dommages à personnes ou choses causés par une mauvaise installation de ses appareils d'éclairage. Les coordonnées mentionnées sont purement indicatives; il est possible que des erreurs d'impression y figurent.































Axo Light se reserva el derecho de aportar a los propios modelos, sin ningún preaviso, cualquier modificación que se considere oportuna. Axo Light no responde por los eventuales daños causados a personas o cosas provocados por una incorrecta instalación de los propios aparatos de iluminación. Los datos que aparecen son puramente indicativos; es posible que contengan errores de impresión.

Axo Light reserva-se o direito de efetuar nos modelos, sem nenhum pré-aviso, qualquer modificação que considerar oportuna. Axo Light não responde por eventuais danos a pessoas ou coisas causados por uma instalação incorreta dos próprios aparelhos de iluminação. Os dados reproduzidos são meramente indicativos; é possível que estejam indicados erros de impressão.

Axo Light оставляет за собой право вносить модификации моделей без предупреждения, в случае необходимости. Axo Light не несёт ответственности за ущерб людям или вещам, вызванный некорректной установкой осветительных приборов. Приведенные данные носят иллюстративный характер; возможны опечатки.

INDEX

180	ALRISHA
180	AURA
184	AX20
185	BALIOS
186	BLUM
187	CLAVIUS
190	CRYSTAL SPOTLIGHTS
190	EXPLO
193	FAIRY
195	KOSHI
195	KUDLIK
196	LEIJA
196	MARYLIN
198	MUSE
204	NAFIR
205	NELLY/NELLY STRAIGHT
207	OBI
209	POLIA
209	SHARAV
209	SHIRAZ
210	SLIGHT
211	SPILLRAY
216	SPIRY
216	STORMY
217	SUBZERO
220	SUNSHADE
221	UKIYO
222	URIEL
223	VASILY

-  E27 incandescent
-  E27 incandescent globe
-  E14 incandescent
-  E14 incandescent
-  E27 fluorescent
-  E27 fluorescent globe
-  E27 fluorescent twist
-  E14 fluorescent
-  E14 fluorescent
-  E14 fluorescent
-  E27 fluorescent
-  GX24q-2 fluorescent
-  2GX13 fluorescent
-  2G11 fluorescent
-  G5 fluorescent
-  G24d-2 fluorescent
-  E27 halogen classic
-  E14 halogen classic
-  G9 halogen
-  E27 halogen
-  G4 halogen
-  GY 6.35 halogen
-  GU4 halogen
-  GU5.3 halogen
-  GU10 halogen
-  E14 PAR halogen
-  G53 halogen
-  R7s halogen
-  GU5.3 LED
-  GU10 LED

Verificare dimensioni ed ingombri delle lampadine LED e CFL self ballasted consigliate nel presente catalogo, prima dell'acquisto. Fornitura lampadine LED su richiesta.

Before any purchase, please verify size and dimensions of the LED and CFL self-ballasted bulbs recommended in this catalogue. Supply of LED bulbs on request.

Le schede tecniche dei prodotti Axo Light sono scaricabili direttamente dal nostro sito: www.axolight.it

Axo Light technical sheets can be downloaded directly from our website: www.axolight.it

Die Axo Light Produktdatenblätter können direkt von unserer Website heruntergeladen werden: www.axolight.it

Les fiches techniques des produits Axo Light peuvent être téléchargés directement de notre site: www.axolight.it

Las fichas técnicas de los productos Axo Light se pueden descargar directamente de nuestro sitio web: www.axolight.it

As fichas técnicas dos produtos Axo Light podem ser baixadas diretamente do nosso site: www.axolight.it

Технические характеристики изделий фирмы Axo Light возможно скачать с нашего сайта: www.axolight.it



I nostri prodotti sono tutti sottoposti alle prove di sicurezza elettrica e conformi alle Direttive Comunitarie Europee EN60598-1, LVD 2006/95/EC, EMC 2004/108/EC, IEC 62471 (ove previsto).

All our products undergo electric safety tests and comply with ECC Directive EN60598-1, LVD 2006/95/EC, EMC 2004/108/EC, IEC 62471 (where provided).

Entsprechend den Europäischen Normen EN60598-1, LVD 2006/95/EC, EMC 2004/108/EC, IEC 62471 (sofern vorgesehen), werden alle Produkte den elektrischen Sicherheitsprüfungen unterzogen.

Tous nos produits sont soumis aux tests de sécurité, et sont conformes aux Directives CEE EN60598-1, LVD 2006/95/EC, EMC 2004/108/EC, IEC 62471 (le cas échéant).

Todos nuestros productos han sido sometidos a las pruebas de seguridad eléctrica y son conformes con las directivas comunitarias europeas EN60598-1, LVD 2006/95/EC, EMC 2004/108/EC, IEC 62471 (en los casos previstos).

Os nossos produtos são todos submetidos aos testes de segurança elétrica e conformes às Diretivas Comunitárias Europeias EN60598-1, LVD 2006/95/EC, EMC 2004/108/EC, IEC 62471 (se previsto).

Все наши изделия проходят испытания на электрическую безопасность и соответствуют директивам Европейского Сообщества EN60598-1, LVD 2006/95/EC, EMC 2004/108/EC, IEC 62471 (в случаях, когда это предусмотрено).



Solo isolamento fondamentale; le parti conduttrici accessibili sono collegate ad un conduttore di terra. Messa a terra obbligatoria.

Basic insulation, accessible conductors are earthed. Earthing is compulsory.

Grundisolation: berührbare Metallteile mit Anschlussstelle für Schutzleiter verbunden. Netzschutzleiter: vorgeschrieben.

Isolation de base: les parties conductrices accessibles sont mises à terre. Mise à terre obligatoire.

Solo aislamiento fundamental; las partes conductoras accesibles están conectadas a un conductor de tierra. Puesta a tierra obligatoria.

Somente isolamento fundamental; as partes condutoras acessíveis são conectadas em um condutor de terra. Aterramento obrigatório.

“Изоляция только базовая. Доступные проводниковые части подсоединены к заземлителю. Заземление обязательно.



Sistema a doppio isolamento; messa a terra esclusa.

Double insulation. Earthing: excluded.

Doppelte Isolierung. Netzschutzleiter: nicht erlaubt.

Double isolation. Mise à la terre: exclue.

Sistema de doble aislamiento; puesta a tierra no incluida.

Sistema com isolamento duplo; aterramento excluído.

Система двойной изоляции. Заземление исключено.



Apparecchio in cui la protezione contro la scossa elettrica si basa sulla alimentazione a bassissima tensione di sicurezza.

Appliance in which protection against electrical shock is guaranteed by the extremely low-voltage power supply.

Zum Schutz vor elektrischen Schlägen mit Niedervolt gespeistes Gerät.

Appareil avec protection contre les décharges életriques basée sur l'alimentation à une tension de sécurité très basse.

Aparato en el cual la protección contra la descarga eléctrica se debe a la alimentación a muy baja tensión.

Aparelho no qual a proteção contra choque elétrico baseia-se na alimentação com baixíssima tensão de segurança.

Прибор, в котором защита от удара током основана на питании от очень низкого напряжения.

IPXY

Grado di protezione contro corpi solidi X – e contro i liquidi Y.

Protection rating against solid bodies X – against liquids Y.

Schutzgrad X gegen feste Körper – Schutzgrad Y gegen Flüssigkeiten.

Niveau de protection contre corps solides X – et contre les liquides Y.

Grado de protección contra cuerpos sólidos X – y contra los líquidos Y.

Grau de proteção contra corpos sólidos X – e contra os líquidos Y.

Степень защиты от проникновения твердых тел X и жидкостей Y.



Predisposto con variatore di luce.

With dimmer.

Mit Dimmer.

Avec dimmer.

Con dimmer.

Predisposto com variador de luz.

Предусмотрено с диммер.



Dimmerabile solo con driver dedicato.

Dimmable only with dedicated power supply unit.

Nur mit dem vorgesehenen Treiber dimmbar.

Dimmerable uniquement avec driver spécifique.

Regulable sólo con driver específico.

Atenuável somente com unidade de abastecimento de potência dedicada.

Регулировка яркости возможна только со специальным блоком питания.



Articolo dimmerabile 1-10V.

Dimmable 1-10V.

Article pouvant être muni d'un variateur de lumière 1-10V.

Dimmbare Ausführung 1–10 V.



Artículo dimmerable 1-10V.

Artigo regulável dimmer 1-10V.

регулятор яркости 1-10В.

ALRISHA WHITE VARNISHED FINISHING

AP ALRISH / AP ALRISP

source LED warm light
power 2 x 3 W / 500mA
marks CE   with designated PSU IP20

PSU not included / wire in series

Art. APALRISHXXXXLED

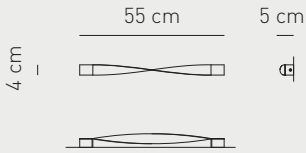

Art. APALRISPXXXXLED

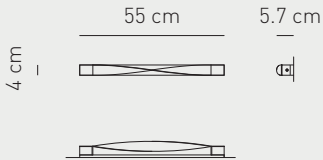

PSU (driver) must be installed
in accessible and remote location.

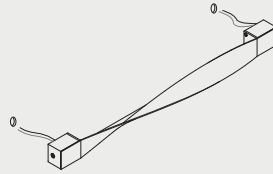

Art. APALRISHXXXXLED



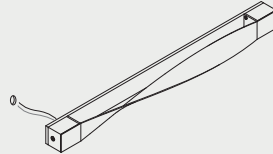

Art. APALRISPXXXXLED



SP ALRISH

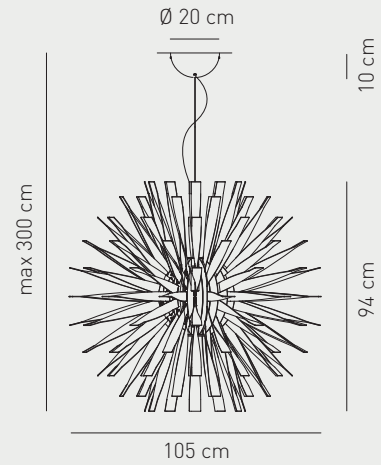

base / bulb type E27 halogen
power 1 x max 150 W
ilcos HSGST/C/UB 
marks CE  IP20

base / bulb type E27 fluorescent
power 1 x max 33 W
ilcos FB 
marks CE  IP20



AURA POLISHED STEEL OR GOLD LEAF FINISHINGS



FA AURA 30

base / bulb type GU5.3 halogen
power 1 x max 35 W
ilcos HAGS/UB 
marks CE 12V  IP20

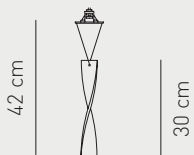
hole \varnothing 6.5 cm / min depth 10 cm





FA AURA 44

base / bulb type GU5.3 halogen
power 1 x max 35 W
ilcos HAGS/UB 
marks CE 12V  IP20

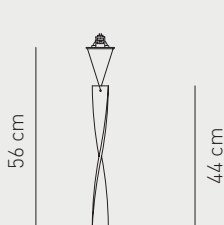
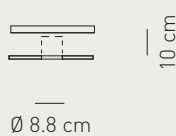
hole \varnothing 6.5 cm / min depth 10 cm





FA AURA 53

base / bulb type GU5.3 halogen
power 1 x max 35 W
ilcos HAGS/UB 
marks CE 12V  IP20

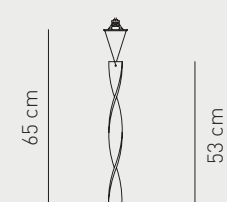
hole \varnothing 6.5 cm / min depth 10 cm





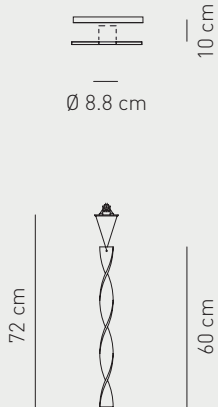

FA AURA 60

base / bulb type GU5.3 halogen
power 1 x max 35 W
ilcos HAGS/UB 
marks  12V 

hole \varnothing 6.5 cm / min depth 10 cm



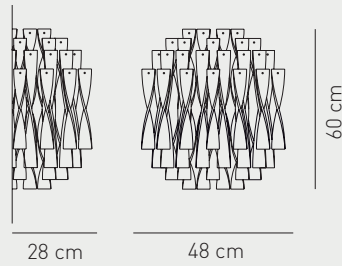

AP AURA

base / bulb type E27 incandescent
or E27 halogen
power 2 x max 100 W
ilcos IAA/C or HSGST/C/UB  / 
marks  



PL AUR P 30

base / bulb type E27 halogen
power 4 x max 100 W
ilcos HSGST/C/UB 
marks  

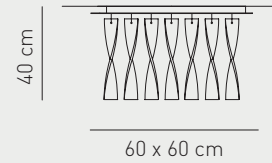



polished steel
finishings



gold leaf
finishings



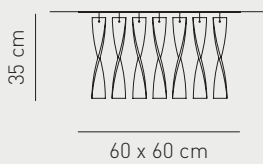

PL AU P 30 I

base / bulb type E27 halogen
power 4 x max 100 W
ilcos HSGST/C/UB 
marks  



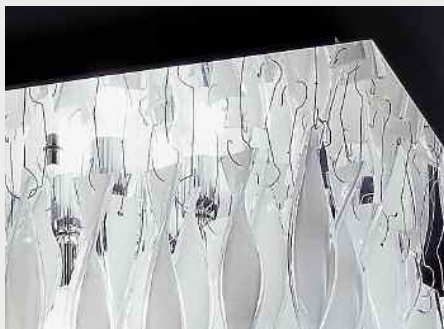
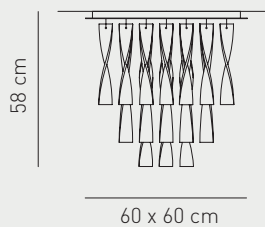

PL AURA P

base / bulb type E27 halogen
power 4 x max 100 W
ilcos HSGST/C/UB 
marks  



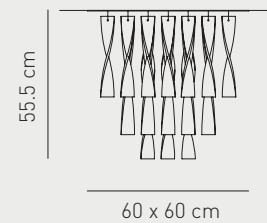

PL AURA P I

base / bulb type E27 halogen
power 4 x max 100 W
ilcos HSGST/C/UB 
marks  



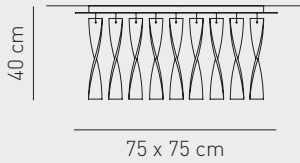

PL AUR G 30

base / bulb type E27 halogen
power 4 x max 100 W
ilcos HSGST/C/UB 
marks  



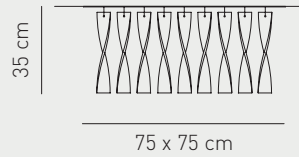

PL AUR G 30 I

base / bulb type E27 halogen
power 4 x max 100 W
ilcos HSGST/C/UB 
marks  



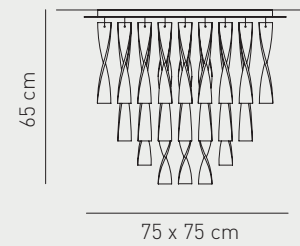

PL AURA GR

base / bulb type E27 halogen
power 4 x max 100 W
ilcos HSGST/C/UB 
marks  



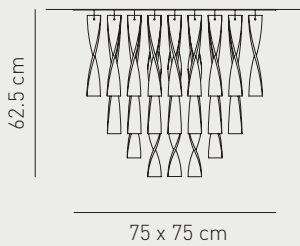

PL AURA G I

base / bulb type E27 halogen
power 4 x max 100 W
ilcos HSGST/C/UB 
marks  



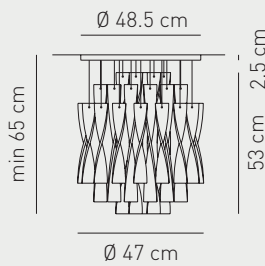

PL AURA 45

base / bulb type E27 halogen
power 1 x max 150 W
ilcos HSGST/C/UB 
marks  



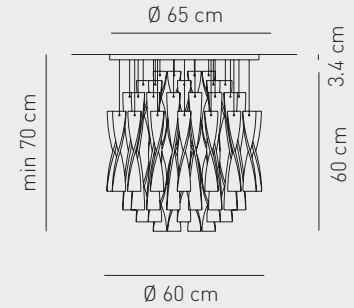

PL AURA 60

base / bulb type E27 halogen
power 1 x max 250 W
ilcos HSGST/C/UB 
marks  



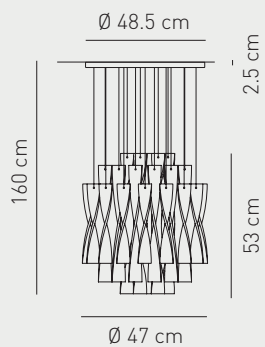

SP AURA 45

base / bulb type E27 halogen
power 1 x max 150 W
ilcos HSGST/C/UB 
marks CE  IP20



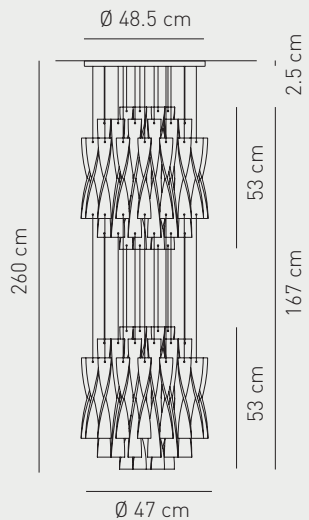

SP AU 45/2

base / bulb type E27 halogen
power 2 x max 150 W
ilcos HSGST/C/UB 
marks CE  IP20



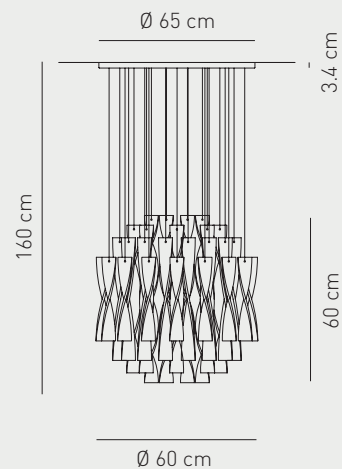

SP AURA 60

base / bulb type E27 halogen
power 1 x max 250 W
ilcos HSGST/C/UB 
marks CE  IP20



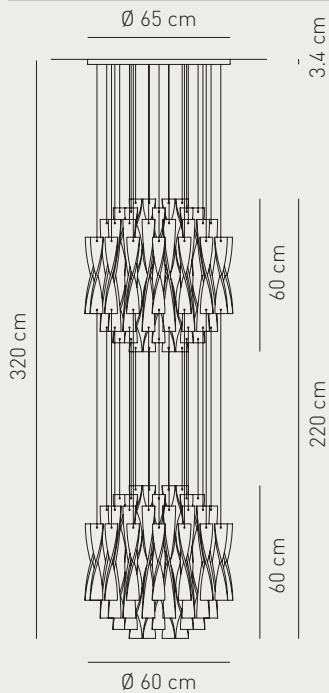

SP AU 60/2

base / bulb type	E27 halogen
power	2 x max 250 W
ilcos	HSGST/C/UB 
marks	CE  IP20





AX20 CHROME-PLATED FINISHINGS

AP AX20 PI

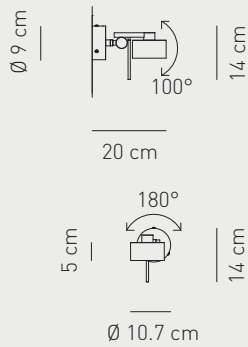
base / bulb type	G9 halogen
power	1 x max 60 W
ilcos	HSGST/C/UB 
marks	CE  IP20



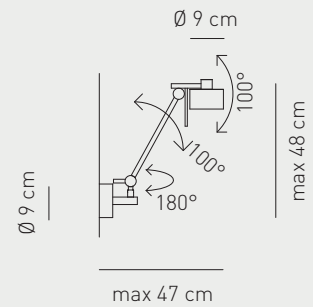

AP AX20 GR

base / bulb type	G9 halogen
power	1 x max 60 W
ilcos	HSGST/C/UB 
marks	CE  IP20





SP AX20 PI

base / bulb type	G9 halogen
power	1 x max 60 W
ilcos	HSGST/C/UB 
marks	CE  IP20



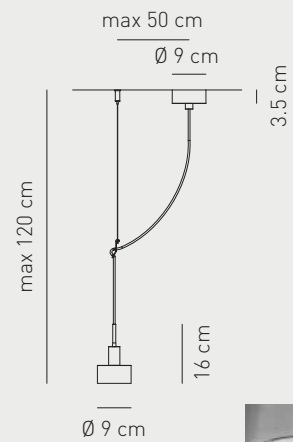

SP AX20 DE

base / bulb type	G9 halogen
power	1 x max 60 W
ilcos	HSGST/C/UB 
marks	CE  IP20



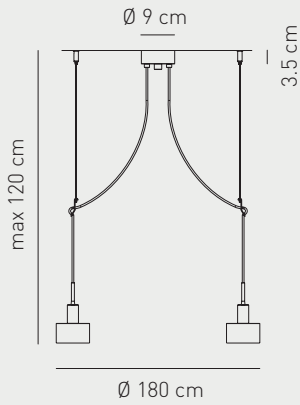

2 X SP AX20 DE

base / bulb type G9 halogen
power 2 x max 60 W
ilcos HSGST/C/UB 
marks CE  IP20



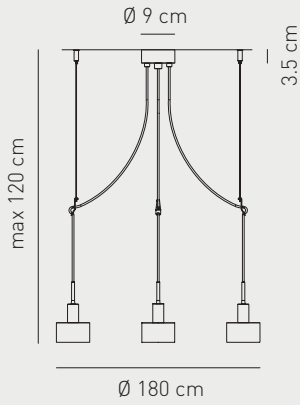

3 X SP AX20 DE

base / bulb type G9 halogen
power 3 x max 60 W
ilcos HSGST/C/UB 
marks CE  IP20



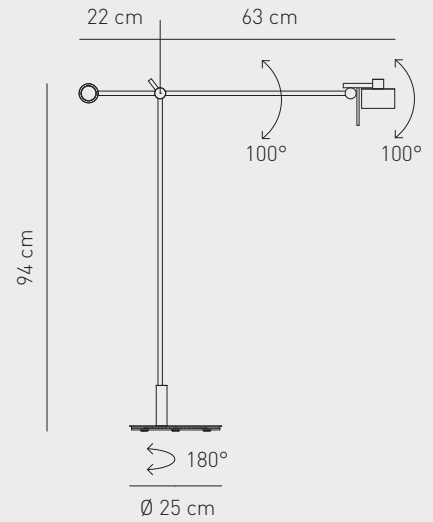

PT AX20

base / bulb type G9 halogen
power 1 x max 60 W
ilcos HSGST/C/UB 
marks CE  IP20



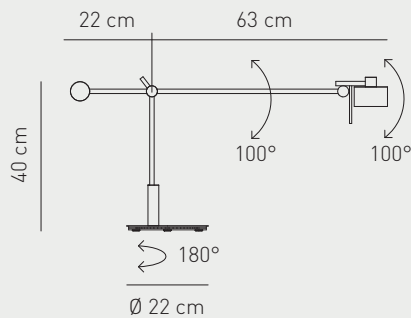

LT AX20

base / bulb type G9 halogen
power 1 x max 60 W
ilcos HSGST/C/UB 
marks CE  IP20





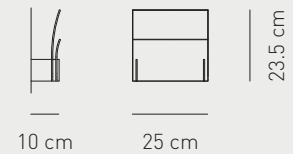

BALIOS CHROME-PLATED FINISHINGS

AP BALI 25

base / bulb type R7s halogen
power 1 x max 100 W (78)
ilcos HDG 
marks CE  IP20





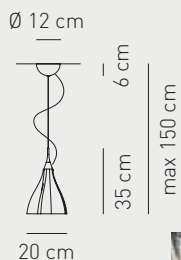

SP BLUM 1

base / bulb type E14 incandescent
 power 1 x max 60 W
 ilcos IBP/C 
 marks   





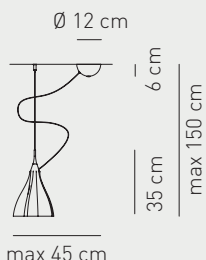

SP BLU DEC

base / bulb type E14 incandescent
 power 1 x max 60 W
 ilcos IBP/C 
 marks   





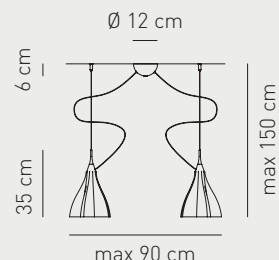

2 X SP BLU DEC

base / bulb type E14 incandescent
 power 2 x max 60 W
 ilcos IBP/C 
 marks   





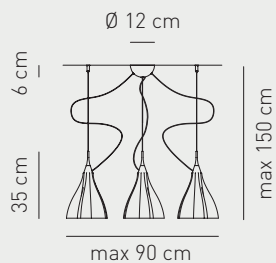

3 X SP BLU DEC

base / bulb type E14 incandescent
 power 3 x max 60 W
 ilcos IBP/C 
 marks   





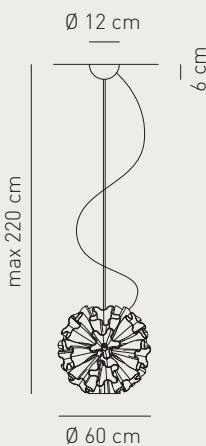

SP BLUM 19

base / bulb type E14 incandescent
 power 19 x max 60 W
 ilcos IBP/C 
 marks   



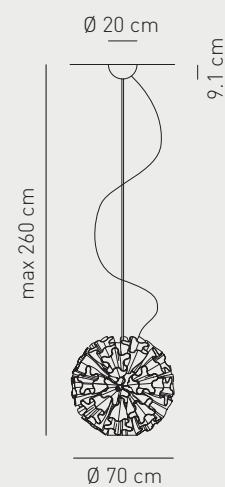

SP BLUM 31

base / bulb type E14 incandescent
 power 31 x max 60 W
 ilcos IBP/C 
 marks   



FA CLAVIU

base / bulb type GU5.3 halogen
 power 1 x max 35 W
 ilcos HAGS/UB 
 marks **CE** 12V 

hole Ø 6.5 cm / min depth 10 cm

10 cm





10 cm





4 cm

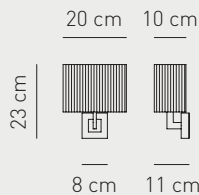

AP CLAV BR

base / bulb type E14 incandescent
 power 1 x max 60 W
 ilcos IBB/C 
 marks **CE** 





AP CLAV 30

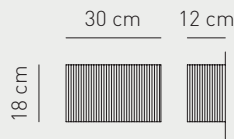

base / bulb type E14 incandescent
 power 1 x max 60 W
 ilcos IBB/C 
 marks **CE** 

base / bulb type G24d-2 fluorescent
 power 1 x 18 W
 ilcos FSQ 
 marks **CE** 





AP CLAV GR

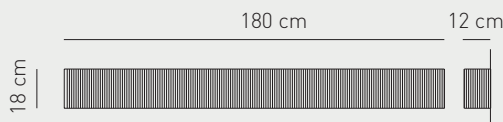

base / bulb type E14 incandescent
 power 6 x max 60 W
 ilcos IBB/C 
 marks **CE** 



base / bulb type G5 fluorescent
 power 2 x 24 W
 ilcos FDH 
 marks **CE** 



AP CLAV 45

base / bulb type E14 incandescent
 power 2 x max 40 W
 ilcos IBB/C 
 marks **CE** 

base / bulb type GX24q-2 fluorescent
 power 2 x 18 W
 ilcos FSQ 
 marks **CE** 

base / bulb type E14 halogen + G9 halogen
 power 2 x max 40 W +
 1 x max 25 W
 ilcos HAGS/UB + HSGST/C/UB 
 marks **CE** 

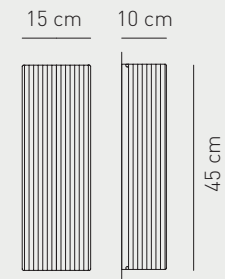

AP CLAV PI

base / bulb type E14 incandescent
power 2 x max 60 W
ilcos IBB/C 
marks CE IP20

base / bulb type 2G11 fluorescent
power 1 x 36 W
ilcos FSDH 
marks CE IP20

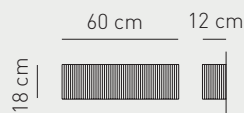

PL CLAVIU

base / bulb type E27 incandescent
power 3 x max 60 W
ilcos IAA/C 
marks CE IP20

base / bulb type 2GX13 fluorescent
power 1 x 55 W
ilcos FC-55 
marks CE IP20

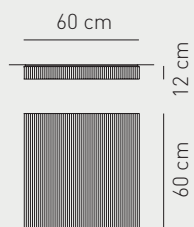

SP CLAV 40

base / bulb type E27 incandescent
power 4 x max 60 W
ilcos IAA/C 
marks CE IP20

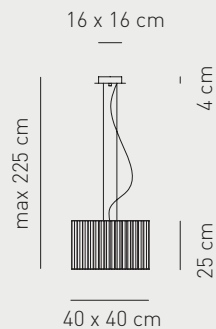

SP CLAVI P

base / bulb type E27 incandescent
power 2 x max 100 W
ilcos IAA/C 
marks CE IP20

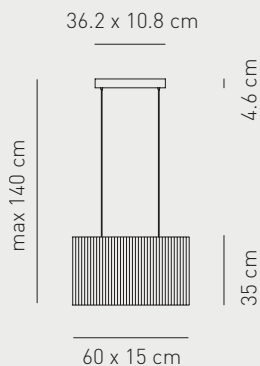

SP CLAV 60

base / bulb type E27 incandescent
power 4 x max 100 W
ilcos IAA/C 
marks CE IP20

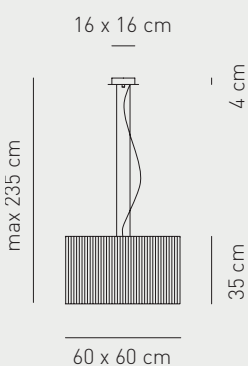

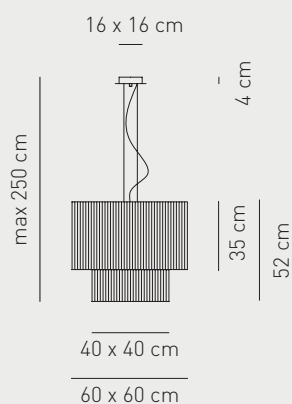

SP CL 60 40

base / bulb type E27 incandescent
power 4 x max 100 W
ilcos IAA/C 
marks CE IP20



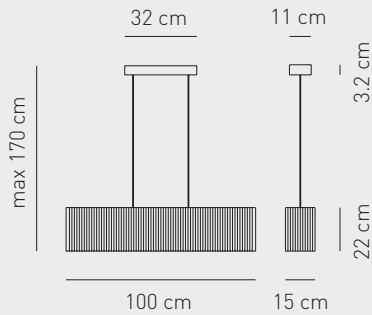

SP CLAVIU E27

base / bulb type E27 incandescent
power 3 x max 100 W
ilcos IAA/C 
marks CE   IP20



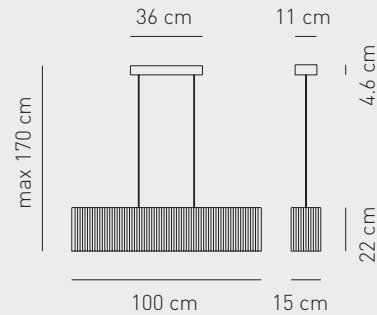

SP CLAVIU FLE

base / bulb type G5 fluorescent
power 1 x 39 W
ilcos FDH 
marks CE   IP20



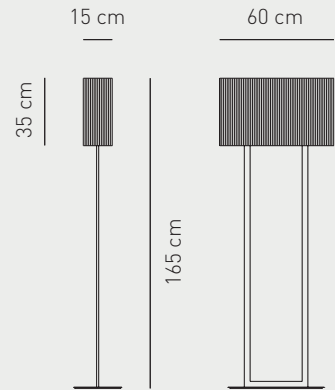

PT CLAVIU

base / bulb type E27 incandescent
power 2 x max 100 W
ilcos IAA/C 
marks CE   IP20



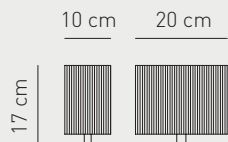

LT CLAV XP

base / bulb type E14 incandescent
power 1 x max 60 W
ilcos IBB/C 
marks CE   IP20



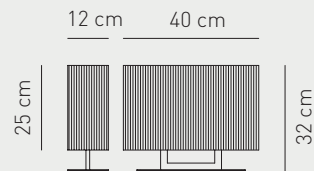

LT CLAVI P

base / bulb type E14 incandescent
power 2 x max 60 W
ilcos IBB/C 
marks CE   IP20



LT CLAVI G

base / bulb type E27 incandescent
power 2 x max 100 W
ilcos IAA/C 
marks CE   IP20

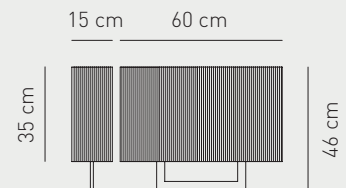

CRYSTAL SPOTLIGHT CRYSTAL WITH METAL FITTINGS

FA MENCAR

base / bulb type G9 halogen
 power 1 x max 40 W
 ilcos HSGST/C/UB 
 marks CE \oplus IP20

base / bulb type GY 6.35 halogen
 power 1 x max 35 W
 ilcos HSGST/C/UB 
 marks CE 12V \diamond IP20

base / bulb type GU4 halogen
 power 1 x max 35 W dicr
 ilcos HRGS/UB \triangleleft
 marks CE 12V \diamond IP20

hole \varnothing 5.5 cm / min depth 10 cm

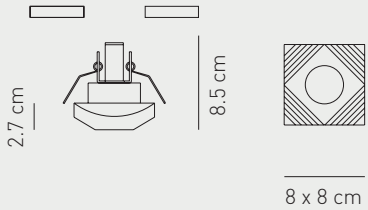

FA NASHIR

base / bulb type G9 halogen
 power 1 x max 40 W
 ilcos HSGST/C/UB 
 marks CE \oplus IP20

base / bulb type GY 6.35 halogen
 power 1 x max 35 W
 ilcos HSGST/C/UB 
 marks CE 12V \diamond IP20

base / bulb type GU4 halogen
 power 1 x max 35 W dicr
 ilcos HRGS/UB \triangleleft
 marks CE 12V \diamond IP20

hole \varnothing 5.5 cm / min depth 10 cm

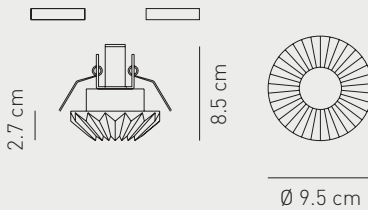



EXPLO WHITE PAINTED METAL AND STEEL FINISHINGS

SP EXPL0 5

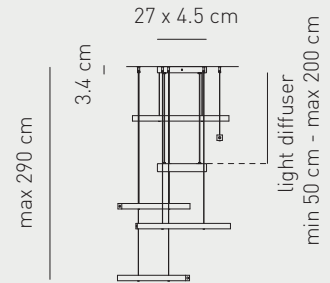
base / bulb type R7s halogen
 power 1 x max 120 W (118mm)
 ilcos HDG 
 marks CE \oplus IP20





SP EXPL I 5

base / bulb type R7s halogen
 power 1 x max 120 W (118mm)
 ilcos HDG 
 marks CE  IP20

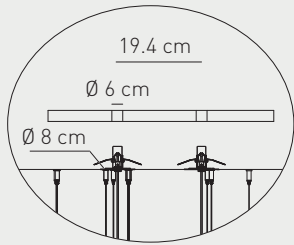
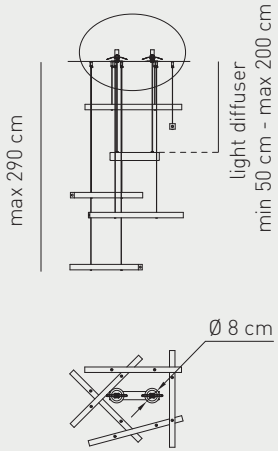
hole Ø 6 cm / min depth 10 cm



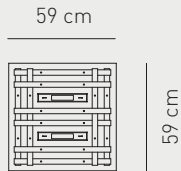
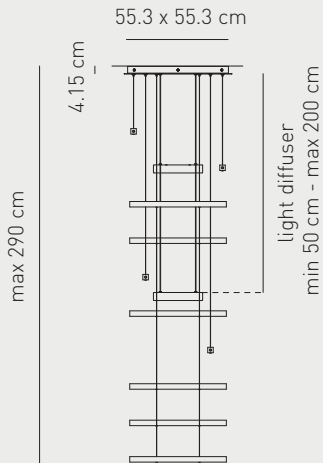

SP EXP Q 10

base / bulb type R7s halogen
 power 2 x max 120 W (118mm)
 ilcos HDG 
 marks CE  IP20



SP EXPL 10

base / bulb type R7s halogen
 power 3 x max 120 W (118mm)
 ilcos HDG 
 marks CE  IP20

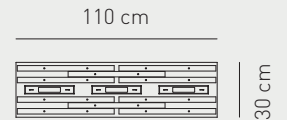
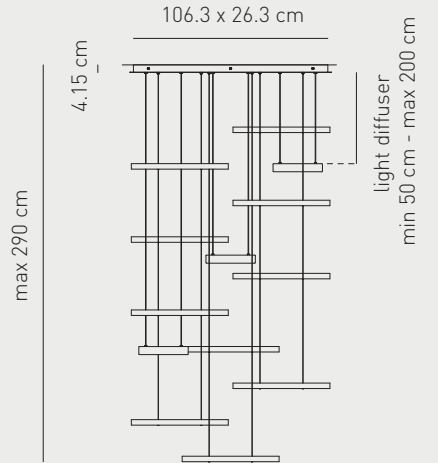

CUSTOMIZED PROJECT EXAMPLES

SINGLE: 15 GLASS BARS & 2 LIGHT DIFFUSERS

- SP EXPL I 5 (x 2)
- + V EXPLO (x 5)
- + INTERM EXPLO (x 10)

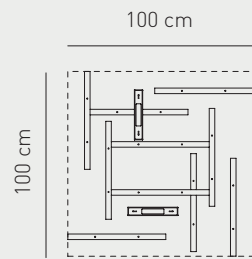
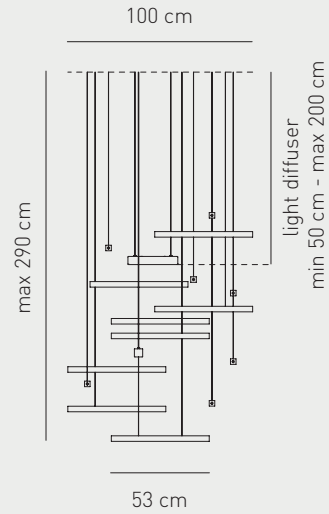

DOUBLE: 30 GLASS BARS & 4 LIGHT DIFFUSERS

- SP EXPL I 5 (x 4)
- + V EXPLO (x 10)
- + INTERM EXPLO (x 20)

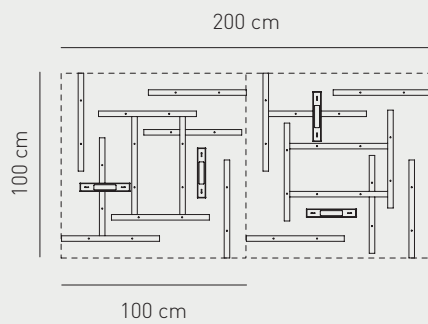
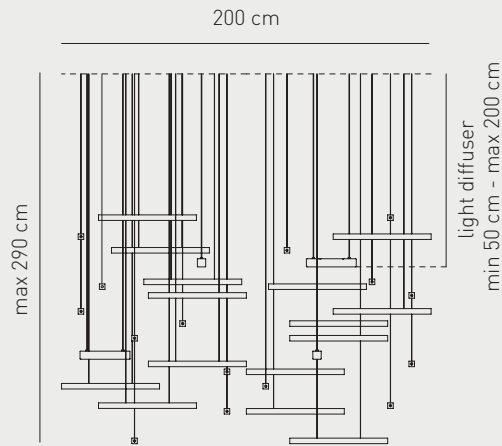

QUADRUPLE: 60 GLASS BARS & 8 LIGHT DIFFUSERS

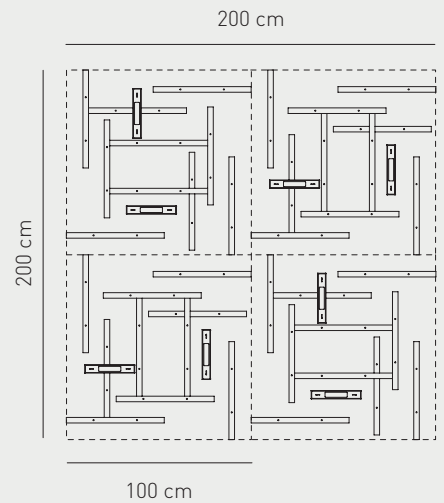
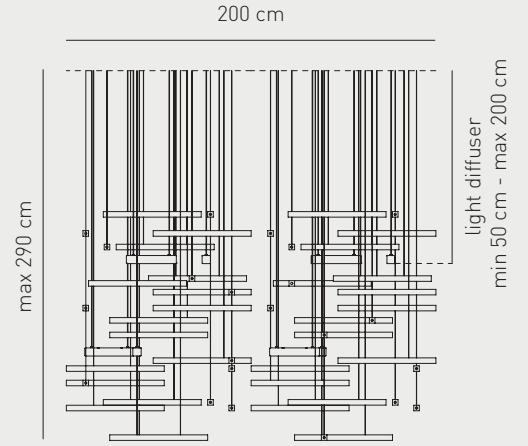

- SP EXPL I 5 (x 8)
- + V EXPLO (x 20)
- + INTERM EXPLO (x 40)



These items will be available in our price lists from January 2014. Models supplied with template.





FA FAIRY

source LED warm light
 power 1 x 6.6 W / 350mA
 marks    IP20

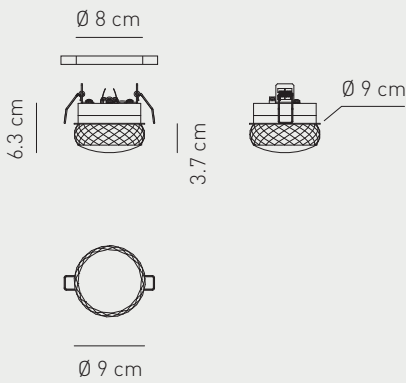
hole \varnothing 8 cm / min depth 10 cm
 PSU not included / Wire in series



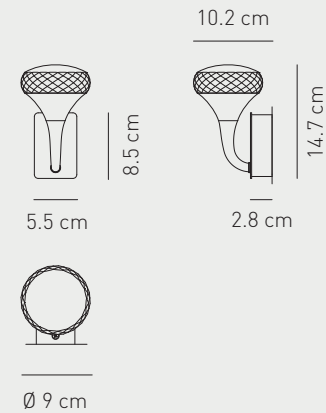

AP FAIRY

source LED warm light
 power 1 x 6.6 W
 marks   IP44



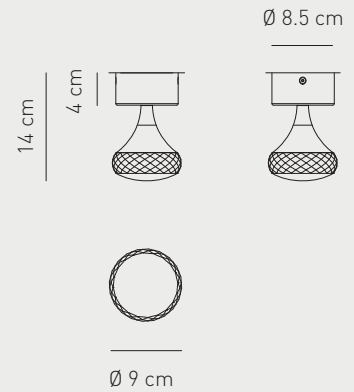

PL FAIRY

source LED warm light
 power 1 x 6.6 W
 marks   IP20





PL FAIRY I

source LED warm light
 power 1 x 6.6 W / 350mA
 marks    IP20

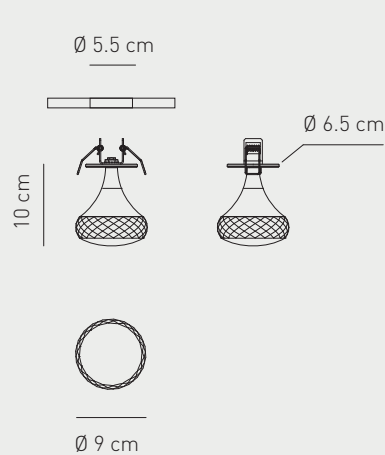
hole \varnothing 5.5 cm / min depth 10 cm
 PSU not included / Wire in series



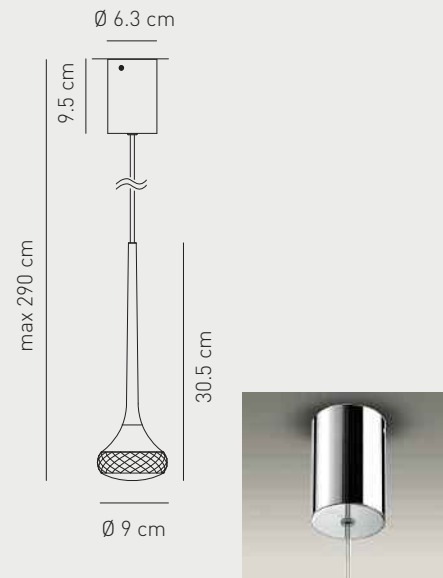

SP FAIRY

source LED warm light
 power 1 x 6.6 W
 marks   IP20



SP FAIRY I

source LED warm light
 power 1 x 6.6 W / 350mA
 marks    IP20

hole \varnothing 5.5 cm / min depth 10 cm
 PSU not included / Wire in series

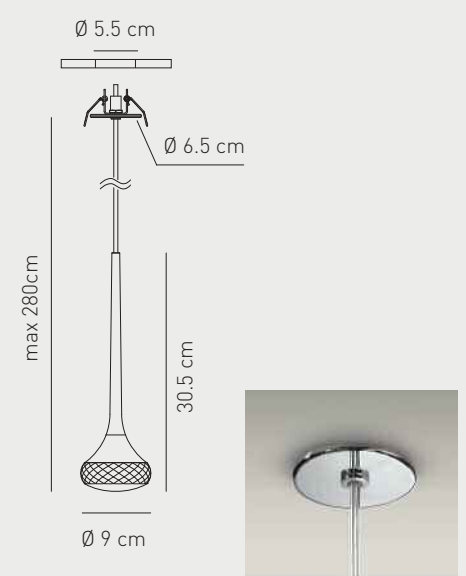

SP FAI 12 R

source LED warm light
 power 12 x 6.6 W
 marks CE  IP20

white varnished canopy

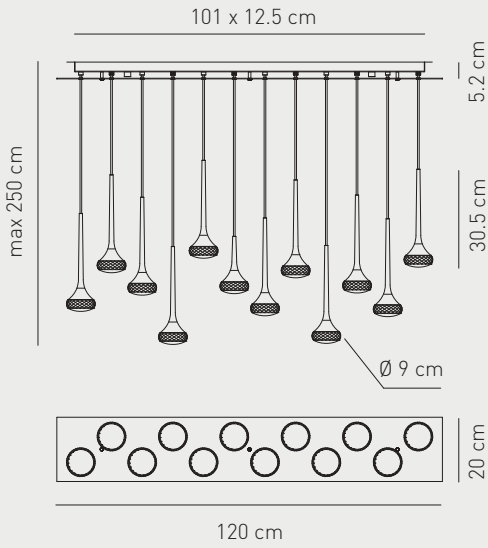

SP FAIR 12

source LED warm light
 power 12 x 6.6 W
 marks CE  IP20

white varnished canopy

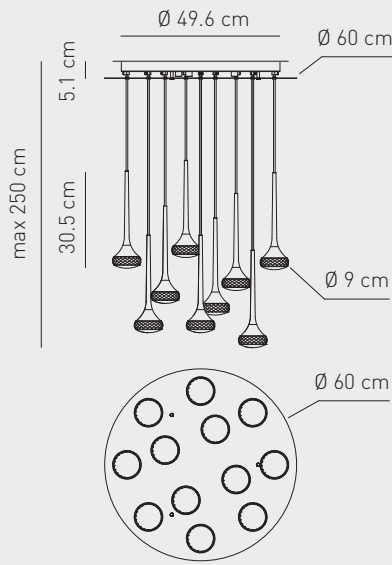

SP FAIR 12 with optional chromed rings
 Ø60 & Ø100 cm

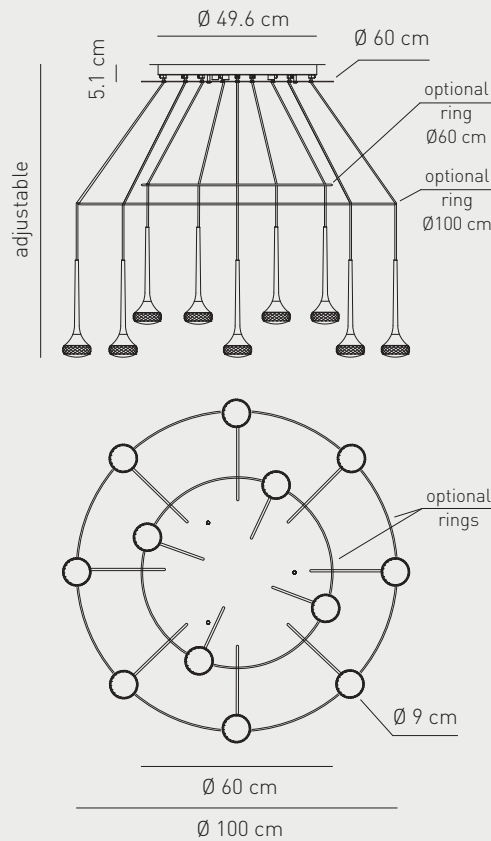

SP FAIR 18

source LED warm light
 power 18 x 6.6 W
 marks CE  IP20

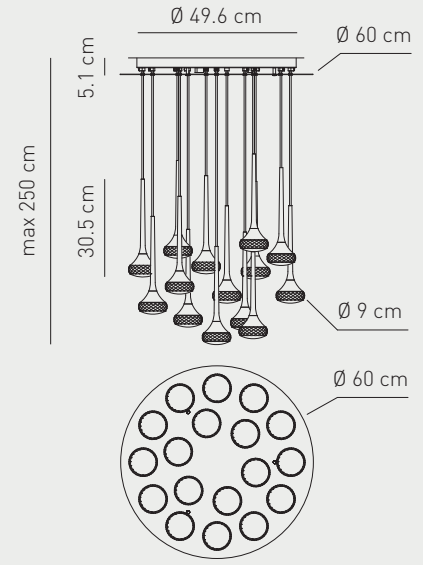

white varnished canopy

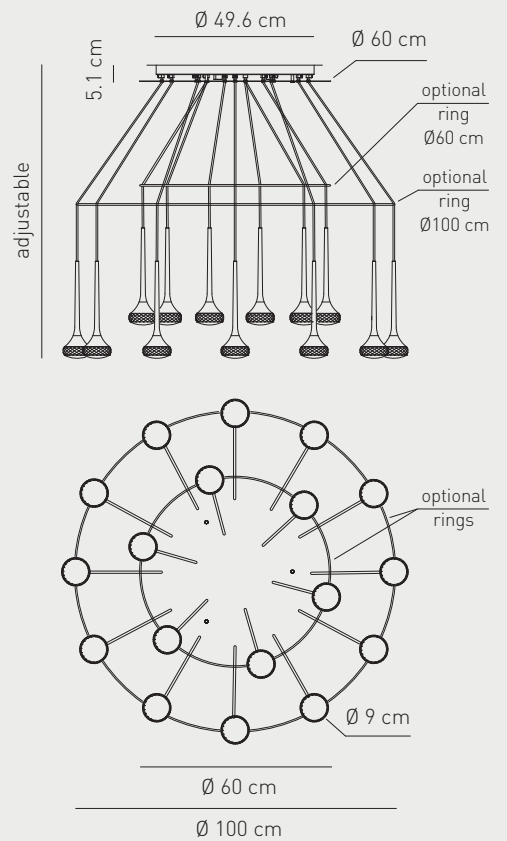

SP FAIR 18 with optional chromed rings
 Ø60 & Ø100 cm



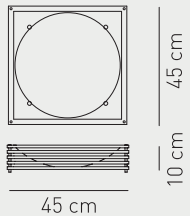

PL KOSHI

base / bulb type R7s halogen
 power 1 x max 150 W (118)
 ilcos HDG 
 marks CE   IP20



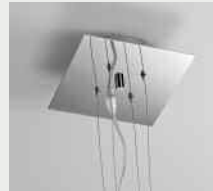
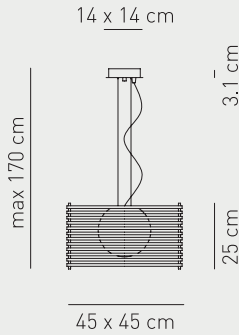

SP KOSHI M

base / bulb type E27 halogen
 power 1 x max 100 W
 ilcos HSGST/C/UB 
 marks CE   IP20



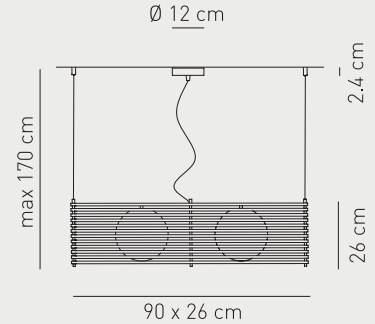

SP KOSHI G

base / bulb type E27 halogen
 power 2 x max 100 W
 ilcos HSGST/C/UB 
 marks CE   IP20







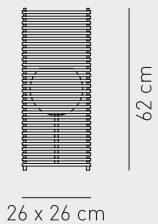

LT KOSHI G

base / bulb type E27 halogen
 power 1 x max 100 W
 ilcos HSGST/C/UB 
 marks CE   IP20





SP KUDL 35

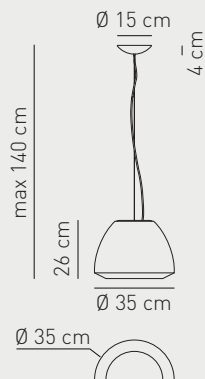

base / bulb type E27 fluorescent twist
 power 1 x max 18 W
 ilcos FB 
 marks CE   IP20

base / bulb type E27 halogen eco
 power 1 x max 150 W
 ilcos HSGST/C/UB 
 marks CE   IP20



SP KUDL 50

base / bulb type E27 fluorescent twist
 power 1 x max 23 W
 ilcos FB 
 marks CE   IP20

base / bulb type E27 halogen eco
 power 1 x max 150 W
 ilcos HSGST/C/UB 
 marks CE   IP20

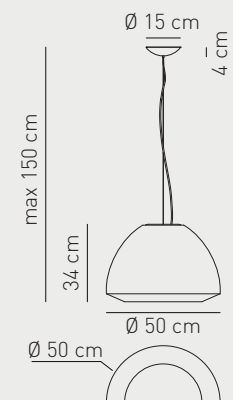

LEIJA WHITE VARNISHED FINISHING

SP LEIJA

base / bulb type 2GX13 fluorescent
power 1 x max 22 W + 1 x max 40 W
ilcos FSCH ○
marks CE ⊕ IP20

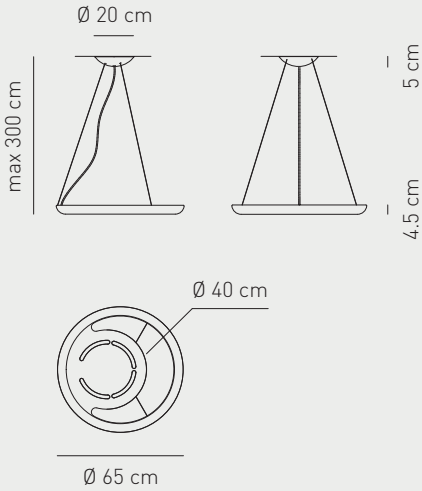

PT LEIJA

base / bulb type 2GX13 fluorescent
power 1 x max 22 W + 1 x max 40 W
ilcos FC ○
marks CE ⊕ IP20

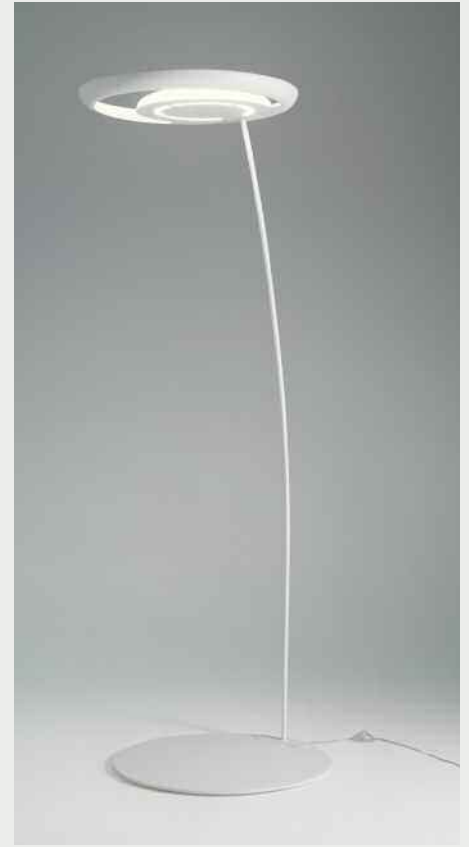
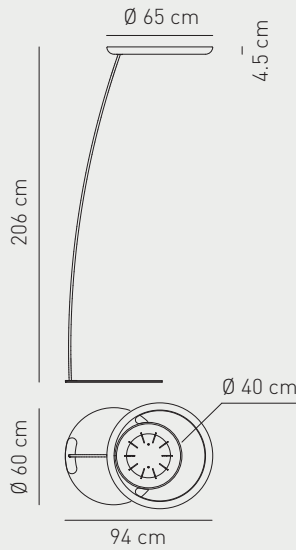

MARYLIN MATT NICKEL FINISHINGS

FA MARYLI

base / bulb type GU5.3 halogen
power 1 x max 35 W
ilcos HAGS/UB ⚠
marks CE ⊕ 12V IP20

hole Ø 6.5 cm / min depth 10 cm

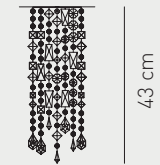

17.5 x 10 cm

AP MARYLI

base / bulb type E27 incandescent
power 1 x max 60 W
ilcos IAA/C ⚡
marks CE ⊕ IP20



10 cm

32 cm

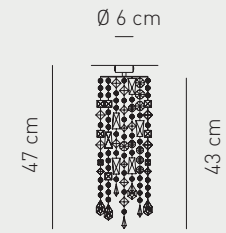

PL MARY 12

base / bulb type G9 halogen
power 1 x max 60 W
ilcos HSGST/C/UB ⚡
marks CE ⊕ IP20





15.5 x 6.5 cm

PL MARY 66

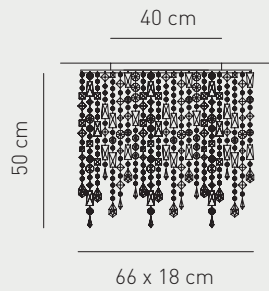
base / bulb type G9 halogen
power 4 x max 60 W
ilcos HSGST/C/UB 
marks CE  IP20



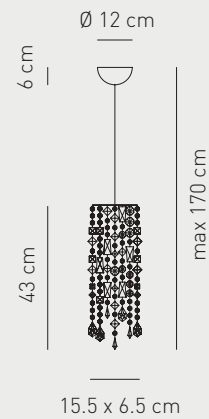

SP MARYL P

base / bulb type G9 halogen
power 1 x max 40 W
ilcos HSGST/C/UB 
marks CE  IP20



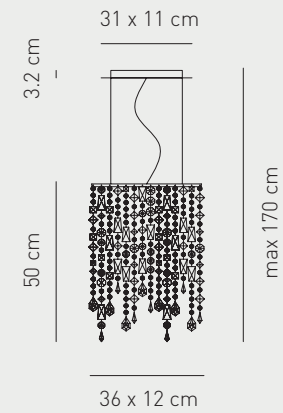

SP MARY 36

base / bulb type G9 halogen
power 1 x max 60 W
ilcos HSGST/C/UB 
marks CE  IP20



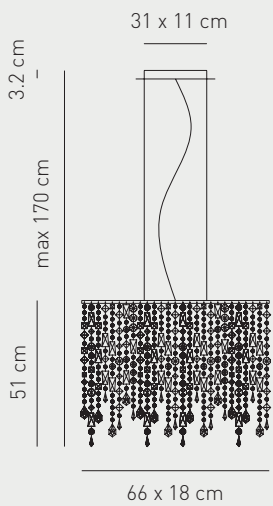

SP MARYLI

base / bulb type G9 halogen
power 4 x max 60 W
ilcos HSGST/C/UB 
marks CE  IP20



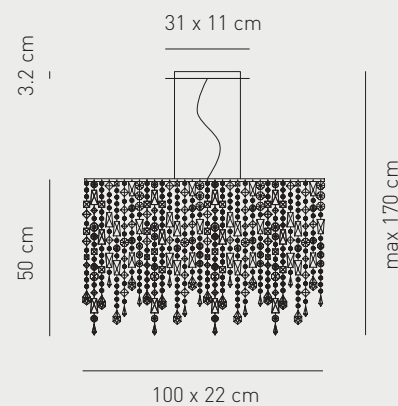

SP MAR 100

base / bulb type G9 halogen
power 6 x max 60 W
ilcos HSGST/C/UB 
marks CE  IP20





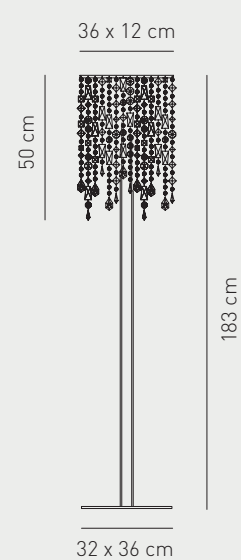

PT MARYLI



base / bulb type E27 incandescent
power 1 x max 150 W
ilcos IAA/C 
marks CE   IP20



PL MUSE 40

base / bulb type E27 incandescent
 power 1 x max 60 W
 ilcos IAA/C 
 marks CE  IP20



base / bulb type E27 halogen
 power 1 x max 42 W
 ilcos HSGSA/UB 
 marks CE  IP20

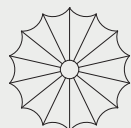
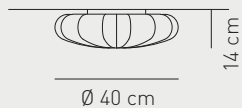

base / bulb type E27 fluorescent
 power 1 x max 13 W
 ilcos FB-CFL 
 marks CE  IP20



application: both as ceiling or wall lamp



PL MUSE 60

base / bulb type E27 incandescent
 power 2 x max 60 W
 ilcos IAA/C 
 marks CE  IP20



base / bulb type E27 halogen
 power 2 x max 42 W
 ilcos HSGSA/UB 
 marks CE  IP20

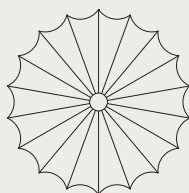
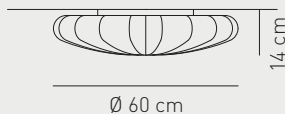

base / bulb type E27 fluorescent
 power 2 x max 13 W
 ilcos FB-CFL 
 marks CE  IP20



application: both as ceiling or wall lamp





PL MUSE 80

base / bulb type E27 incandescent*
 power 3 x max 100 W
 ilcos IAA/C 
 marks CE  IP20

base / bulb type E27 halogen*
 power 3 x max 70 W
 ilcos HSGSA/UB 
 marks CE  IP20



base / bulb type E27 fluorescent
 power 3 x max 23 W
 ilcos FB-CFL 
 marks CE  IP20

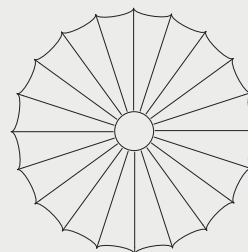
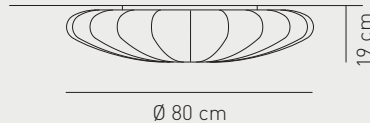

base / bulb type 2GX13
 power 1 x 55 W
 ilcos FC 
 marks CE  IP20



application: both as ceiling or wall lamp
 *only without Kit diffuser KPLMUSE





PL MUS 120

base / bulb type E27 incandescent*
power 3 x max 100 W
ilcos IAA/C 
marks CE  IP20

base / bulb type E27 halogen*
power 3 x max 70 W
ilcos HSGSA/UB 
marks CE  IP20

base / bulb type E27 fluorescent
power 3 x max 23 W
ilcos FB-CFL 
marks CE  IP20



base / bulb type 2GX13
power 1 x 55 W
ilcos FC 
marks CE  IP20

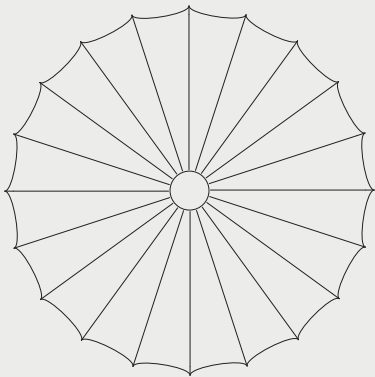
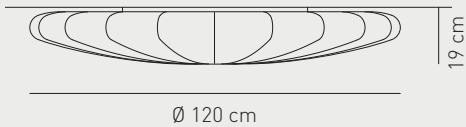

application: both as ceiling or wall lamp
*only without Kit diffuser KPLMUSE





MUSE FIORE

PL MUSE 40 FI

base / bulb type E27 incandescent
power 1 x max 60 W
ilcos IAA/C 
marks CE  IP20



base / bulb type E27 halogen
power 1 x max 42 W
ilcos HSGSA/UB 
marks CE  IP20

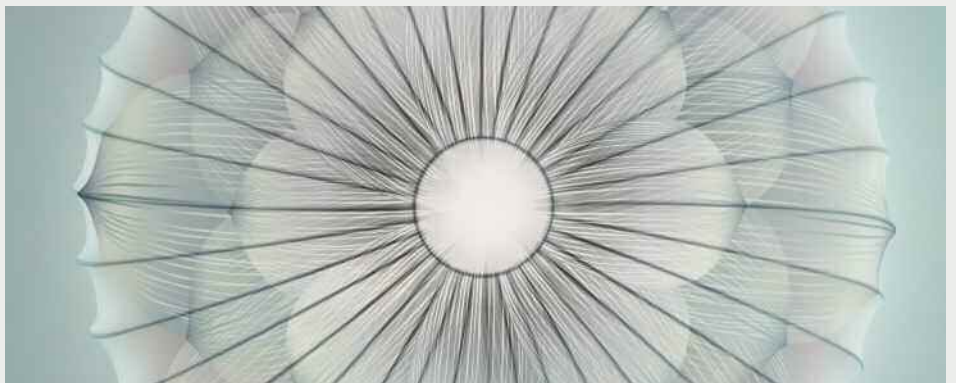
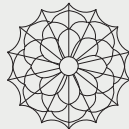
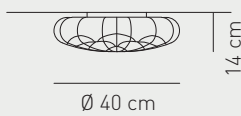

base / bulb type E27 fluorescent
power 1 x max 13 W
ilcos FB-CFL 
marks CE  IP20



application: both as ceiling or wall lamp



PL MUSE 60 FI

base / bulb type E27 incandescent
power 2 x max 60 W
ilcos IAA/C 
marks CE  IP20



base / bulb type E27 halogen
power 2 x max 42 W
ilcos HSGSA/UB 
marks CE  IP20

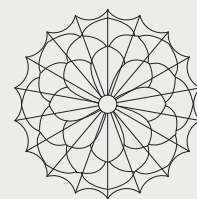
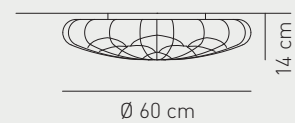

base / bulb type E27 fluorescent
power 2 x max 13 W
ilcos FB-CFL 
marks CE  IP20



application: both as ceiling or wall lamp





PL MUSE 80 FI

base / bulb type E27 incandescent*
 power 3 x max 100 W
 ilcos IAA/C 
 marks CE  IP20



base / bulb type E27 halogen*
 power 3 x max 70 W
 ilcos HSGSA/UB 
 marks CE  IP20



base / bulb type E27 fluorescent
 power 3 x max 23 W
 ilcos FB-CFL 
 marks CE  IP20

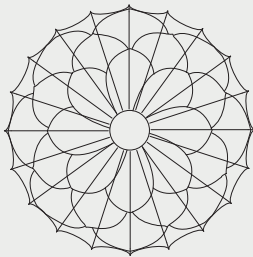
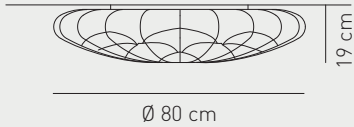

base / bulb type 2GX13
 power 1 x 55 W
 ilcos FC 
 marks CE  IP20



application: both as ceiling or wall lamp
 *only without Kit diffuser KPLMUSE

**PL MUS 120 FI**

base / bulb type E27 incandescent*
 power 3 x max 100 W
 ilcos IAA/C 
 marks CE  IP20



base / bulb type E27 halogen*
 power 3 x max 70 W
 ilcos HSGSA/UB 
 marks CE  IP20



base / bulb type E27 fluorescent
 power 3 x max 23 W
 ilcos FB-CFL 
 marks CE  IP20

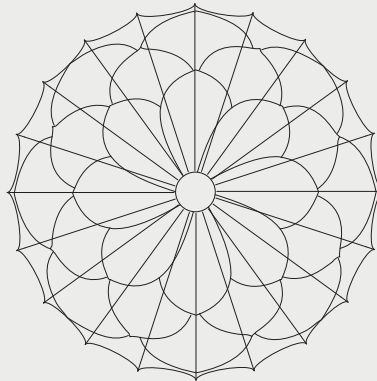
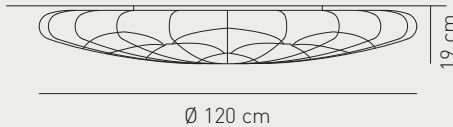

base / bulb type 2GX13
 power 1 x 55 W
 ilcos FC 
 marks CE  IP20

application: both as ceiling or wall lamp
 *only without Kit diffuser KPLMUSE

**MUSE STICKS****PL MUSE 40 ST**

base / bulb type E27 incandescent
 power 1 x max 60 W
 ilcos IAA/C 
 marks CE  IP20



base / bulb type E27 halogen
 power 1 x max 42 W
 ilcos HSGSA/UB 
 marks CE  IP20

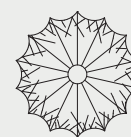
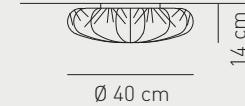

base / bulb type E27 fluorescent
 power 1 x max 13 W
 ilcos FB-CFL 
 marks CE  IP20



application: both as ceiling or wall lamp



PL MUSE 60 ST



base / bulb type E27 incandescent
power 2 x max 60 W
ilcos IAA/C 
marks CE  IP20



base / bulb type E27 halogen
power 2 x max 42 W
ilcos HSGSA/UB 
marks CE  IP20



base / bulb type E27 fluorescent
power 2 x max 13 W
ilcos FB-CFL 
marks CE  IP20



application: both as ceiling or wall lam

PL MUSE 80 ST

base / bulb type E27 incandescent*
power 3 x max 100 W
ilcos IAA/C 
marks CE  IP20



base / bulb type E27 halogen*
power 3 x max 70 W
ilcos HSGSA/UB 
marks CE  IP20



base / bulb type E27 fluorescent
power 3 x max 23 W
ilcos FB-CFL 
marks CE  IP20



base / bulb type 2GX13
power 1 x 55 W
ilcos FC 
marks CE  IP20



application: both as ceiling or wall lamp
*only without Kit diffuser KPLMUSE

PL MUS 120 ST

base / bulb type E27 incandescent*
power 3 x max 100 W
ilcos IAA/C 
marks CE  IP20

base / bulb type E27 halogen*
power 3 x max 70 W
ilcos HSGSA/UB 
marks CE  IP20



base / bulb type E27 fluorescent
power 3 x max 23 W
ilcos FB-CFL 
marks CE  IP20

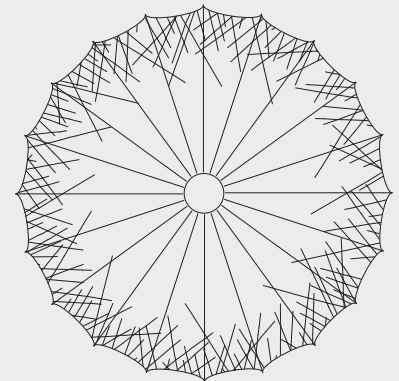
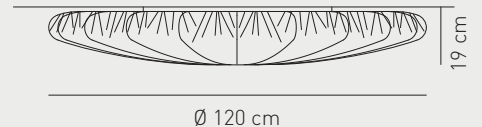
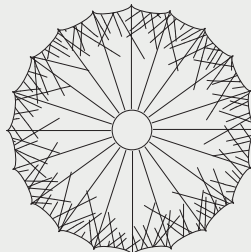
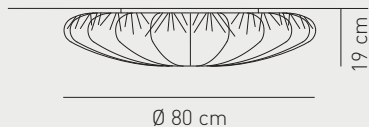
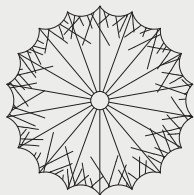
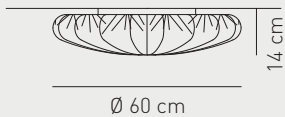

base / bulb type 2GX13
power 1 x 55 W
ilcos FC 
marks CE  IP20



application: both as ceiling or wall lamp
*only without Kit diffuser KPLMUSE



PL MUS 60 Q



base / bulb type E27 incandescent
power 2 x max 60 W
ilcos IAA/C 
marks   IP20



base / bulb type E27 halogen
power 2 x max 42 W
ilcos HSGSA/UB 
marks   IP20



base / bulb type E27 fluorescent
power 2 x max 13 W
ilcos FB-CFL 
marks   IP20



application: both as ceiling or wall lamp

PL MU 120 Q

base / bulb type E27 incandescent*
power 3 x max 100 W
ilcos IAA/C 
marks   IP20



base / bulb type E27 halogen*
power 3 x max 70 W
ilcos HSGSA/UB 
marks   IP20



base / bulb type E27 fluorescent
power 3 x max 23 W
ilcos FB-CFL 
marks   IP20

base / bulb type 2GX13
power 1 x 55 W
ilcos FC 
marks   IP20

application: both as ceiling or wall lamp
*only without Kit diffuser KPLMUSE



SP MUSE 25

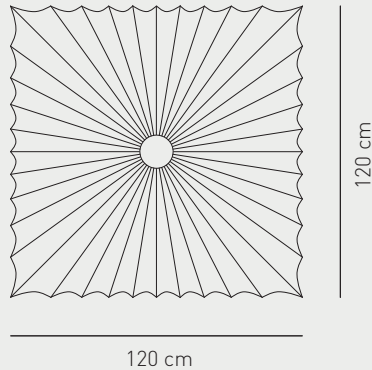
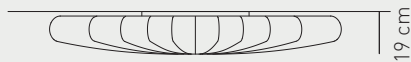
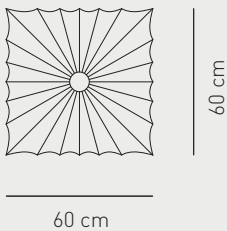
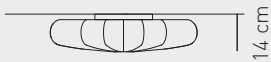
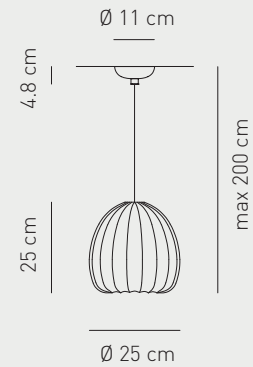

base / bulb type E14 halogen
power 1 x max 42 W
ilcos HSGSP/UB 
marks   IP20

base / bulb type E14 fluorescent
power 1 x max 10 W
ilcos FB-CFL 
marks   IP20









SP MUSE 60

base / bulb type E27 halogen
power 3 x max 105 W
ilcos HSGSA/UB 
marks  



base / bulb type E27 fluorescent
power 3 x max 33 W
ilcos FB-CFL 
marks  



SP MUSE

base / bulb type E27 incandescent globe
power 1 x max 150 W
ilcos IAG/W 
marks  

base / bulb type E27 fluorescent GLOBE
power 1 x max 21 W fluo
ilcos FBG 
marks  

LT MUSE P

base / bulb type E14 halogen
power 1 x max 42 W
ilcos HSGSP/UB 
marks  



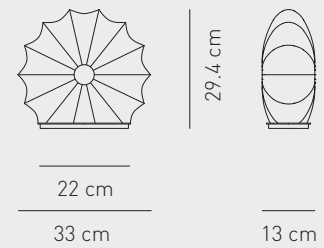
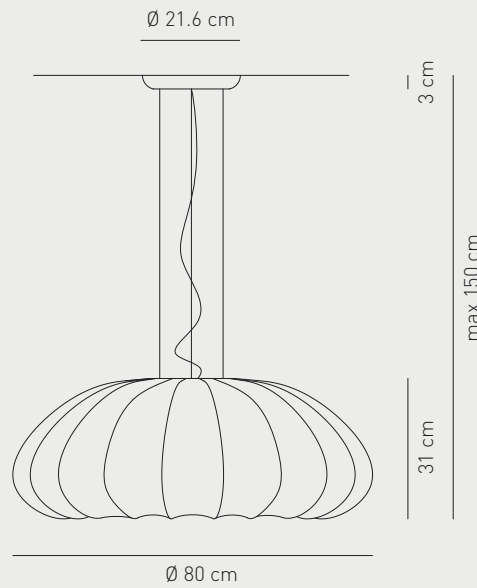
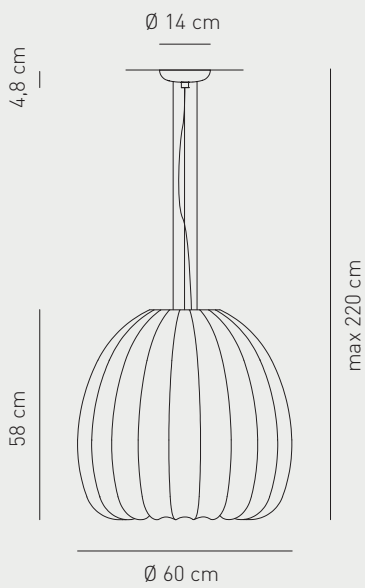

base / bulb type E14 fluorescent
power 1 x max 10 W
ilcos FB-CFL 
marks  







Chrome-plated canopy



LT MUSE G

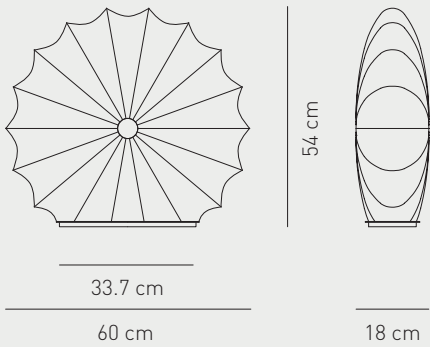

base / bulb type E27 halogen
power 1 x max 105 W
ilcos HSGSA/UB 
marks    IP20

base / bulb type E27 fluorescent
power 1 x max 20 W
ilcos FB-CFL (dim. only) 
marks    IP20



NAFIR WHITE VARNISHED OR GOLDEN FITTINGS



PL NAFIR 1

base / bulb type GU10 LED bulbs
power 1 x max 7.5 W
ilcos DRPAR LED 
marks   IP20

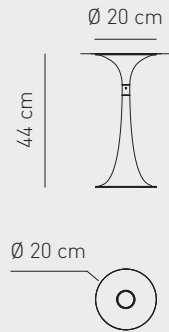
the total height of the bulbs must be between 52 and 62 mm





PL NAFIR 3

base / bulb type GU10 LED bulbs
power 3 x max 7.5 W
ilcos DRPAR LED 
marks   IP20

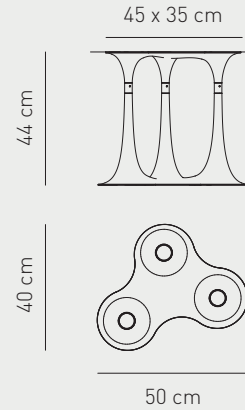
the total height of the bulbs must be between 52 and 62 mm





PL NAFI 3 I (recessed trimless downlights)

base / bulb type GU5.3 LED bulbs
power 3 x max 5 W
ilcos DRR LED 
marks   12V IP20

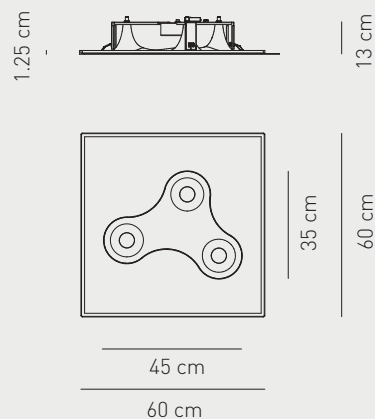
min depth 15 cm (standard ceiling) / 40 cm (false ceiling tiles). The total height of the bulbs must be between 40 and 55 mm





SP NAFIR 1

base / bulb type GU10 LED bulbs
power 1 x max 7.5 W
ilcos DRPAR LED 
marks   IP20

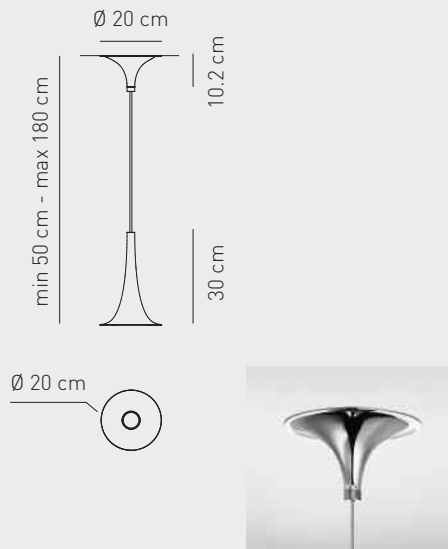
the total height of the bulbs must be between 52 and 62 mm





SP NAFIR 3

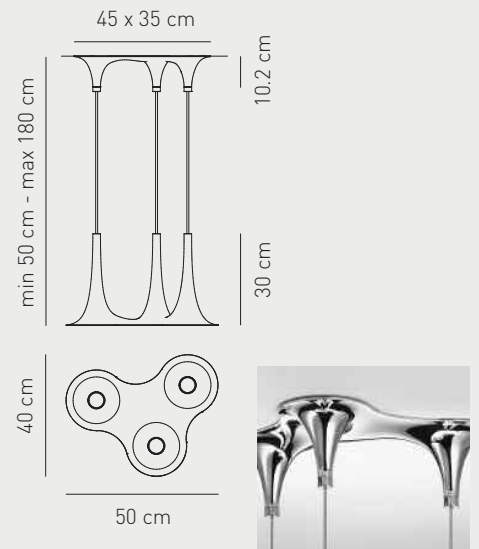

base / bulb type GU10 LED bulbs
power 3 x max 7.5 W
ilcos DRPAR LED 
marks   IP20



the total height of the bulbs must be between 52 and 62 mm





PL NELL 60

base / bulb type E27 incandescent
 power 2 x max 100 W
 ilcos IAA/C 
 marks  

base / bulb type E27 halogen
 power 2 x max 70 W
 ilcos HSGSA/UB 
 marks  



base / bulb type E27 fluorescent
 power 2 x max 20 W fluo
 ilcos FBT 
 marks  

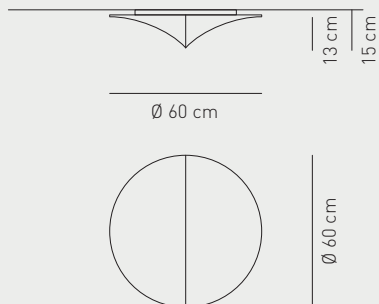

base / bulb type 2GX13 fluorescent
 power 1 x 55 W
 ilcos FC-55 
 marks  



application: both as ceiling or wall lam



PL NEL 100

base / bulb type E27 incandescent
 power 3 x max 100 W
 ilcos IAA/C 
 marks  

base / bulb type E27 halogen
 power 3 x max 70 W
 ilcos HSGSA/UB 
 marks  



base / bulb type E27 fluorescent
 power 3 x max 20 W fluo
 ilcos FBT 
 marks  

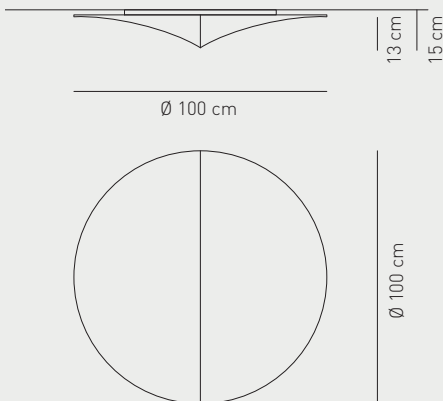

base / bulb type 2GX13 fluorescent
 power 1 x 55 W
 ilcos FC-55 
 marks  



application: both as ceiling or wall lam





PL NEL 140

base / bulb type E27 incandescent
 power 4 x max 100 W
 ilcos IAA/C 
 marks  

base / bulb type E27 halogen
 power 4 x max 70 W
 ilcos HSGSA/UB 
 marks  



base / bulb type E27 fluorescent
 power 4 x max 20 W fluo
 ilcos FBT 
 marks  

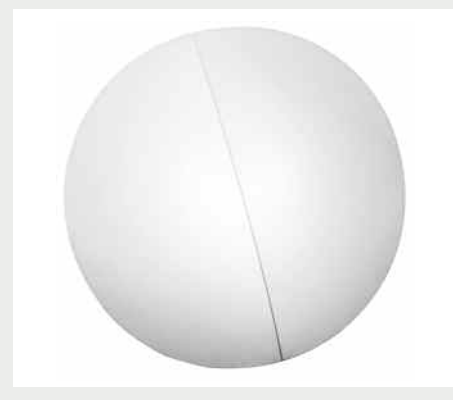
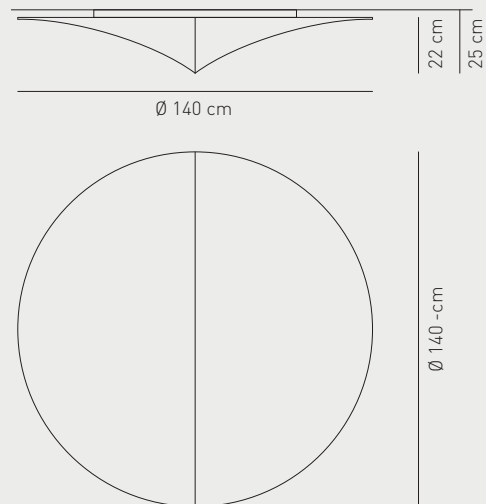

base / bulb type 2GX13 fluorescent
 power 1 x 55 W
 ilcos FC-55 
 marks  



application: both as ceiling or wall lam





PL NEL S 60

base / bulb type E27 incandescent
 power 2 x max 100 W
 ilcos IAA/C 
 marks  

base / bulb type E27 halogen
 power 2 x max 70 W
 ilcos HSGSA/UB 
 marks  



base / bulb type E27 fluorescent
 power 2 x max 20 W fluo
 ilcos FBT 
 marks  

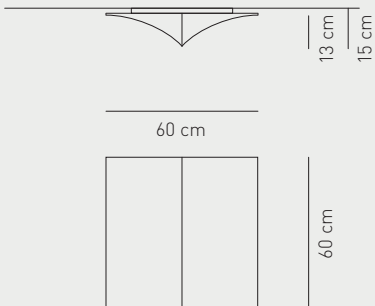

base / bulb type 2GX13 fluorescent
 power 1 x 55 W
 ilcos FC-55 
 marks  



application: both as ceiling or wall lam





PL NE S 100

base / bulb type E27 incandescent
 power 3 x max 100 W
 ilcos IAA/C 
 marks  

base / bulb type E27 halogen
 power 3 x max 70 W
 ilcos HSGSA/UB 
 marks  



base / bulb type E27 fluorescent
 power 3 x max 20 W fluo
 ilcos FBT 
 marks  

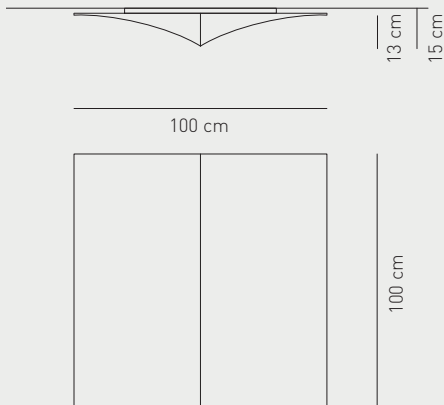

base / bulb type 2GX13 fluorescent
 power 1 x 55 W
 ilcos FC-55 
 marks  



application: both as ceiling or wall lam





PL NE S 140

base / bulb type E27 incandescent
 power 4 x max 100 W
 ilcos IAA/C 
 marks  

base / bulb type E27 halogen
 power 4 x max 70 W
 ilcos HSGSA/UB 
 marks  

base / bulb type E27 fluorescent
 power 4 x max 20 W fluo
 ilcos FBT 
 marks  

base / bulb type 2GX13 fluorescent
 power 1 x 55 W
 ilcos FC-55 
 marks  

application: both as ceiling or wall lam

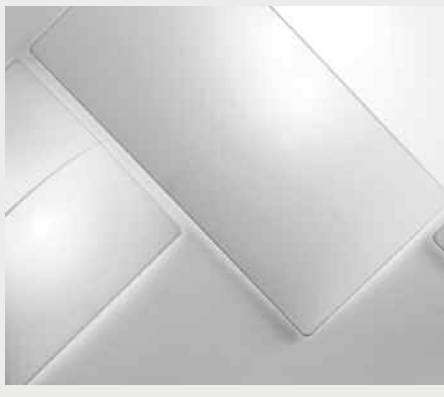
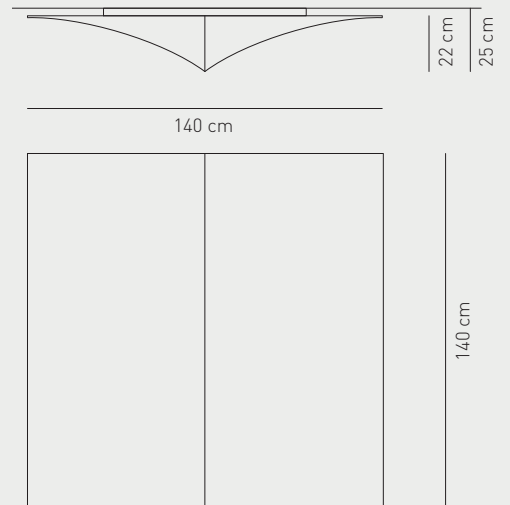

AP OBI

base / bulb type E14 incandescent
 power 2 x max 40 W
 ilcos IBB/C 
 marks CE ⊕ IP20

base / bulb type E14 fluorescent
 power 2 x max 9 W fluo
 ilcos FBC 
 marks CE ⊕ IP20

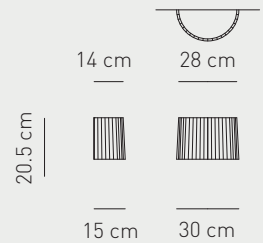

SP OBI 43

base / bulb type E27 incandescent
 power 3 x max 60 W
 ilcos IAA/C 
 marks CE ⊕ IP20

base / bulb type E27 fluorescent
 power 3 x max 20 W fluo
 ilcos FBT 
 marks CE ⊕ IP20

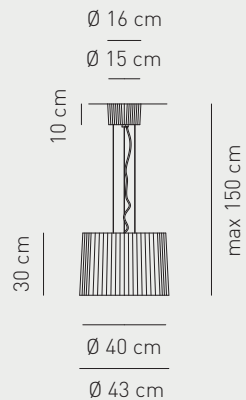

PL OBI

base / bulb type E27 incandescent
 power 3 x max 100 W
 ilcos IAA/C  IP20
 marks CE ⊕

base / bulb type E27 halogen
 power 3 x max 70 W
 ilcos HSGSA/UB 
 marks CE ⊕ IP20

base / bulb type E27 fluorescent
 power 3 x max 20 W fluo
 ilcos FBT 
 marks CE ⊕ IP20

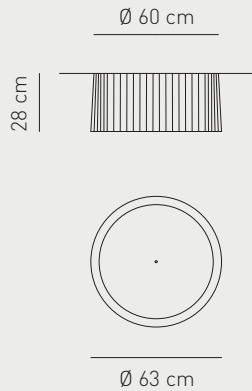

SP OBI 20



base / bulb type E27 incandescent
 power 1 x max 100 W
 ilcos IAA/C 
 marks CE ⊕ IP20

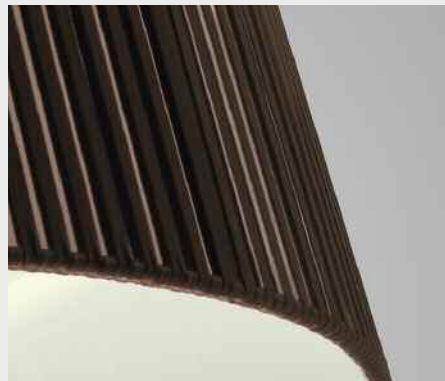
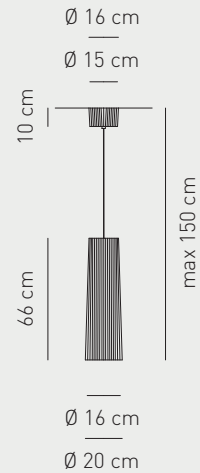

base / bulb type E27 fluorescent
 power 1 x max 20 W fluo
 ilcos FBT 
 marks CE ⊕ IP20

canopy: chrome-plated finishings





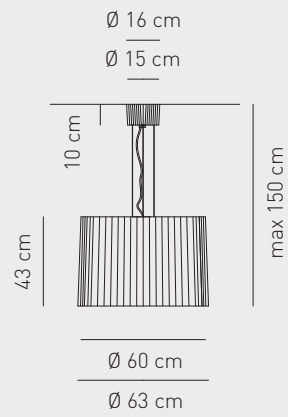

SP OBI 63

base / bulb type E27 incandescent
 power 3 x max 100 W
 ilcos IAA/C 
 marks CE  IP20



base / bulb type E27 fluorescent
 power 3 x max 20 W fluo
 ilcos FBT 
 marks CE  IP20

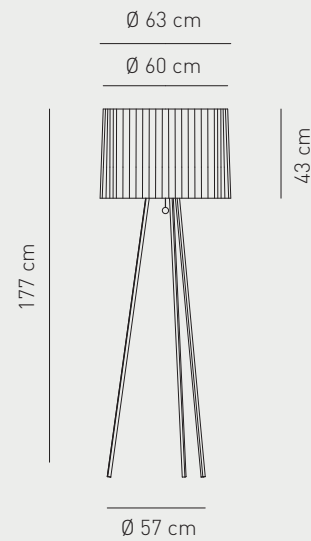

**PT OBI**

base / bulb type E27 incandescent
 power 3 x max 100 W
 ilcos IAA/C 
 marks CE  IP20

base / bulb type E27 fluorescent
 power 3 x max 20 W fluo
 ilcos FBT 
 marks CE  IP20

**LT OBI**

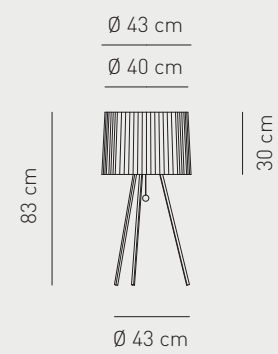

base / bulb type E27 incandescent
 power 3 x max 60 W
 ilcos IAA/C 
 marks CE  IP20

base / bulb type E27 fluorescent
 power 3 x max 10 W fluo
 ilcos FBT 
 marks CE  IP20



POLIA VARNISHED OR COR-TEN EFFECT FINISHINGS

AP POLIA P

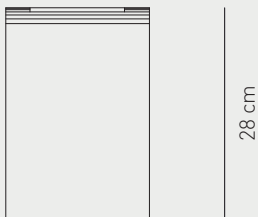

base / bulb type R7s halogen eco
 power 1 x max 120 W (78)
 ilcos HDG 
 marks CE  IP20



19 cm



AP POLIA G

base / bulb type R7s halogen eco
 power 1 x max 160 W (118)
 ilcos HDG 
 marks CE  IP20

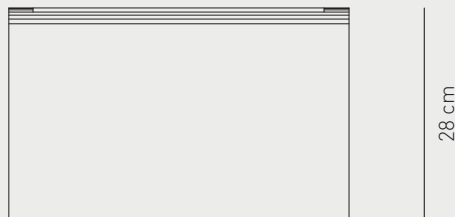





45 cm



SHARAV WHITE METAL PAINTED AND CERAMIC FINISHINGS

AP SHARAV

base / bulb type GU10 halogen
 power 2 x max 40 W
 ilcos HAGS/UB 
 marks CE  IP20

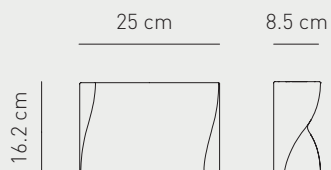

base / bulb type GU10 LED*
 power 2 x max 7.5 W
 ilcos DRPAR 16 LED 
 marks CE  IP20

*the total height of the bulbs must be between 52 and 62 mm



SHIRAZ CHROME-PLATED FINISHINGS



FA SHIRAZ

base / bulb type GU5.3 halogen
 power 1 x max 35 W
 ilcos HAGS/UB 
 marks CE  12V  IP20

hole \varnothing 6.5 cm / min depth 10 cm





PL SHIRA P

base / bulb type R7s halogen
 power 1 x max 60 W (78)
 ilcos HDG 
 marks CE  IP20

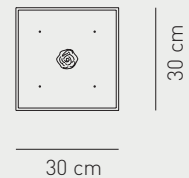
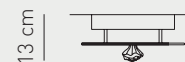
application: both as ceiling or wall lamp





PL SHIRA M

base / bulb type	R7s halogen
power	1 x max 150 W (118)
ilcos	HDG 
marks	CE  IP20

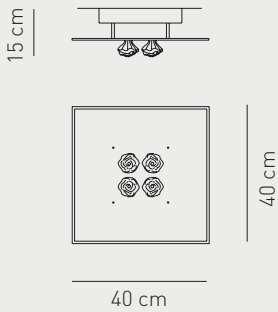
application: both as ceiling or wall lamp



PL SHIRA G



base / bulb type	R7s halogen
power	1 x max 150 W (118)
ilcos	HDG 
marks	CE  IP20

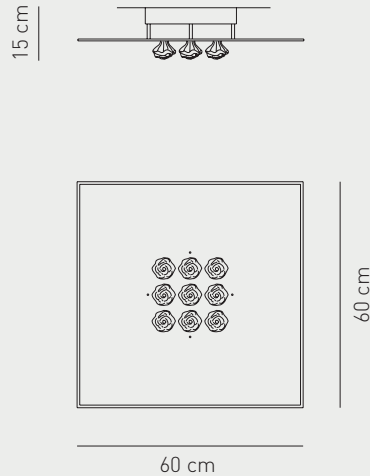

application: both as ceiling or wall lamp



SLIGHT POLISHED STEEL AND METHACRILATE FINISHINGS



AP SLIGHT

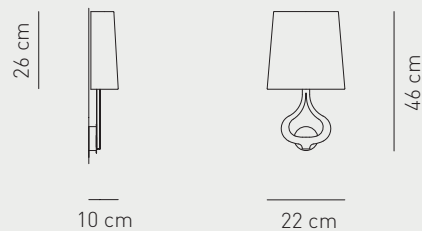

base / bulb type	E14 incandescent
power	1 x max 40 W
ilcos	IBB/C 
marks	CE 

base / bulb type	E14 fluorescent
power	1 x max 9 W fluo
ilcos	FBC 
marks	CE 





SP SLIGHT

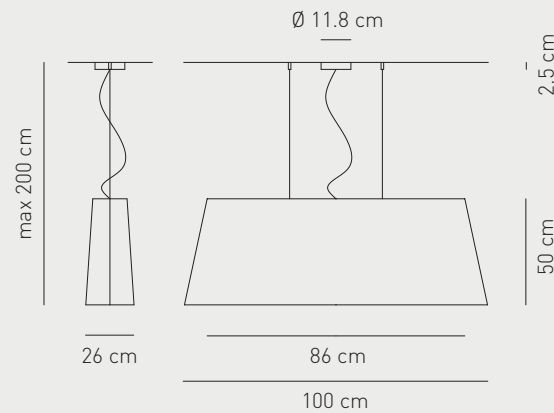

base / bulb type	E27 incandescent
power	2 x max 100 W
ilcos	IAA/C 
marks	CE 

base / bulb type	E27 fluorescent
power	2 x max 20 W fluo
ilcos	FBT 
marks	CE 





LT SLIGH P

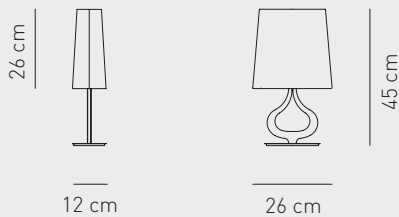

base / bulb type E14 incandescent
power 1 x max 60 W
ilcos IBB/C 
marks CE  IP20

base / bulb type E14 fluorescent
power 1 x max 11 W fluo
ilcos FBC 
marks CE  IP20



LT SLIGH G

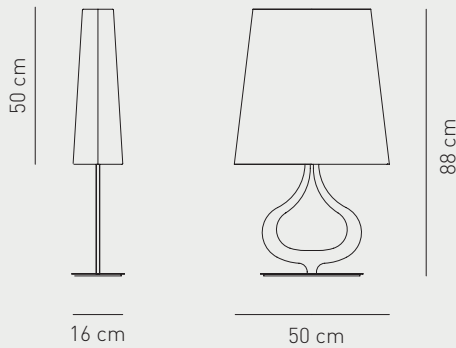

base / bulb type E27 incandescent
power 1 x max 100 W
ilcos IAA/C 
marks CE  IP20

base / bulb type E27 fluorescent
power 1 x max 20 W fluo
ilcos FBT 
marks CE  IP20





SPILLRAY CHROME-PLATED FINISHINGS

AP SPILLR

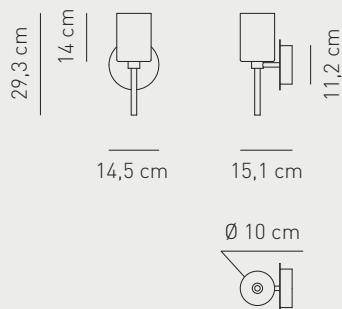
base / bulb type G4 halogen
power 1 x max 20 W
ilcos HSGST/UB 
marks CE  12V IP20





PL SPIL P I

base / bulb type G4 halogen
power 1 x max 20 W
ilcos HSGST/UB 
marks CE  12V IP20

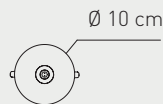
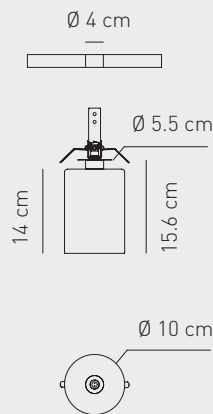
hole \varnothing 4 cm / min depth 10 cm
without transformer





PL SPIL M I

base / bulb type G4 halogen
power 1 x max 20 W
ilcos HSGST/UB 
marks CE  12V IP20

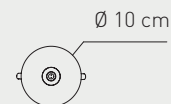
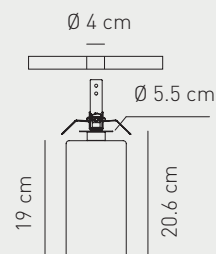
hole \varnothing 4 cm / min depth 10 cm
without transformer





PL SPIL G I

base / bulb type G4 halogen
power 1 x max 20 W
ilcos HSGST/UB 
marks CE   12V IP20

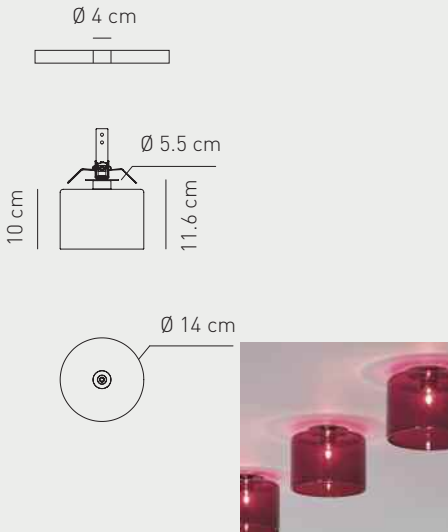
hole \varnothing 4 cm / min depth 10 cm
without transformer



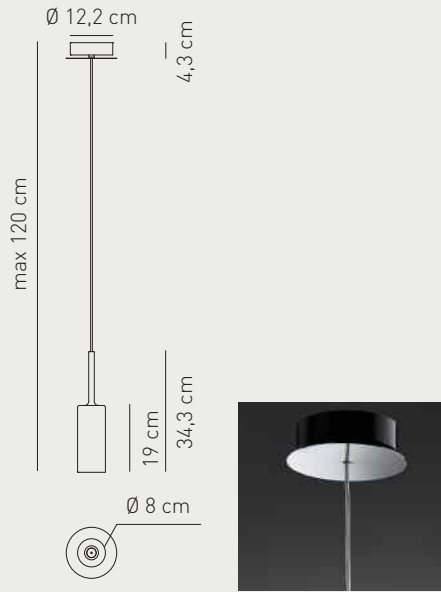

SP SPILL P

base / bulb type G4 halogen
power 1 x max 20 W
ilcos HSGST/UB 
marks CE   12V IP20



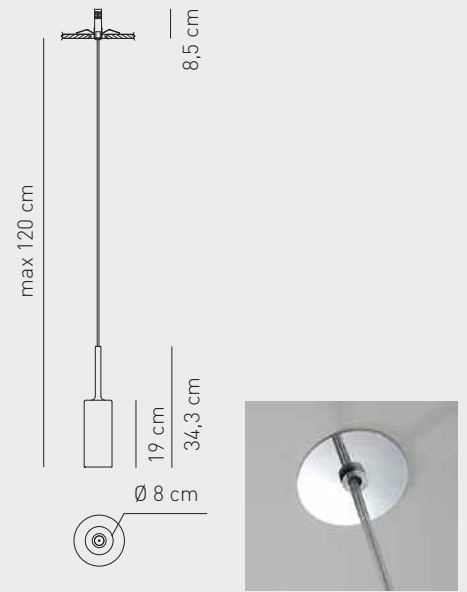

SP SPIL P I

base / bulb type G4 halogen
power 1 x max 20 W
ilcos HSGST/UB 
marks CE   12V IP20



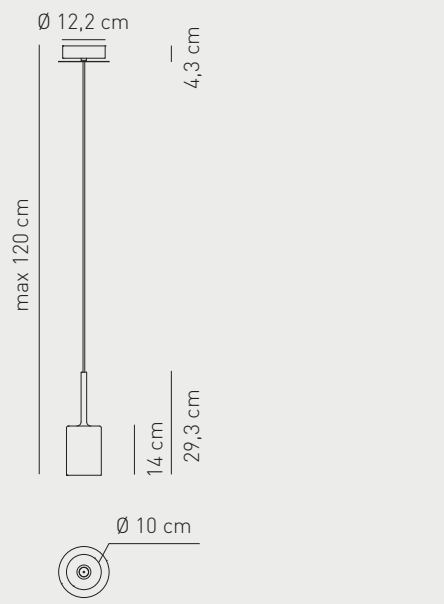

SP SPILL M

base / bulb type G4 halogen
power 1 x max 20 W
ilcos HSGST/UB 
marks CE   12V IP20



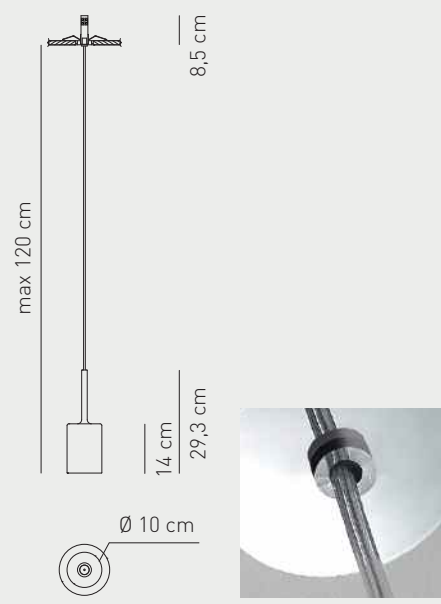

SP SPIL M I

base / bulb type G4 halogen
power 1 x max 20 W
ilcos HSGST/UB 
marks CE   12V IP20



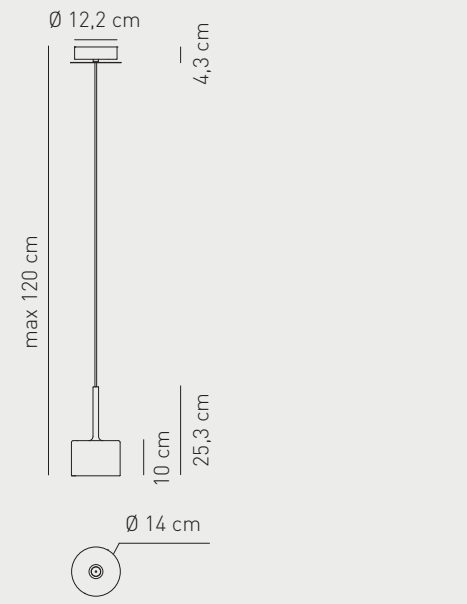

SP SPILL G

base / bulb type G4 halogen
power 1 x max 20 W
ilcos HSGST/UB 
marks CE   12V IP20



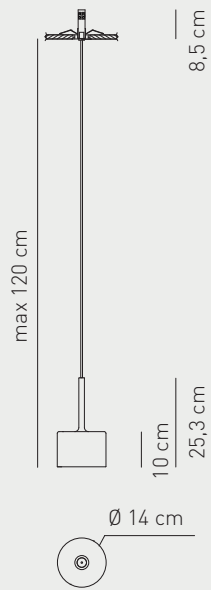

SP SPILL G I

base / bulb type G4 halogen
power 1 x max 20 W
ilcos HSGST/UB 
marks   12V IP20



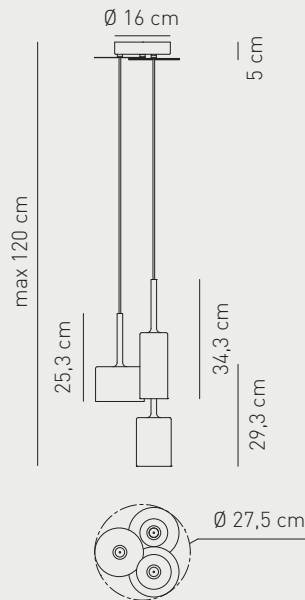

SP SPILL 3

base / bulb type G4 halogen
power 3 x max 20 W
ilcos HSGST/UB 
marks   12V IP20



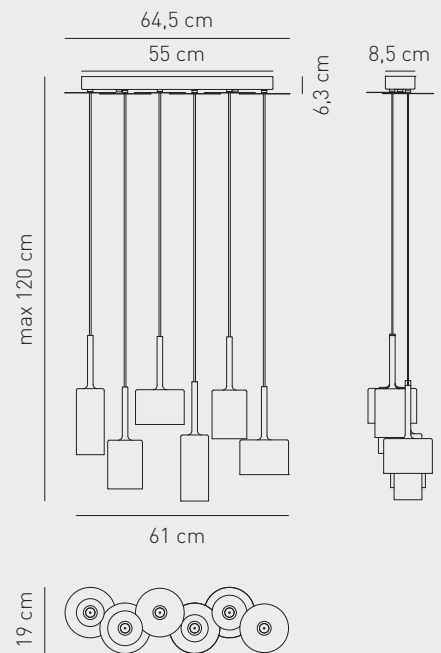

SP SPILL 6

base / bulb type G4 halogen
power 6 x max 20 W
ilcos HSGST/UB 
marks   12V IP20



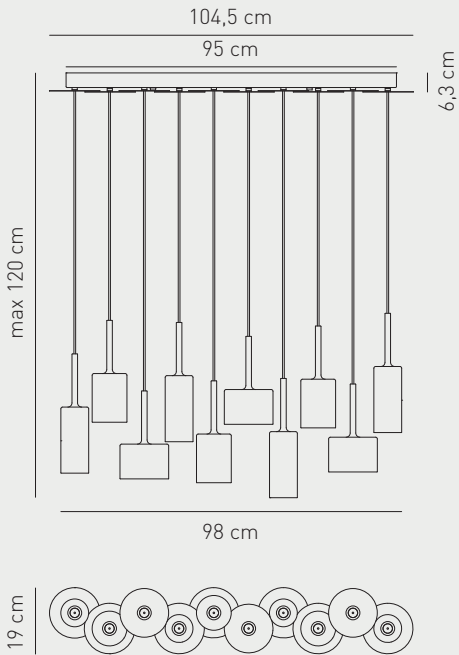

SP SPIL 10

base / bulb type G4 halogen
power 10 x max 20 W
ilcos HSGST/UB 
marks CE  12V IP20



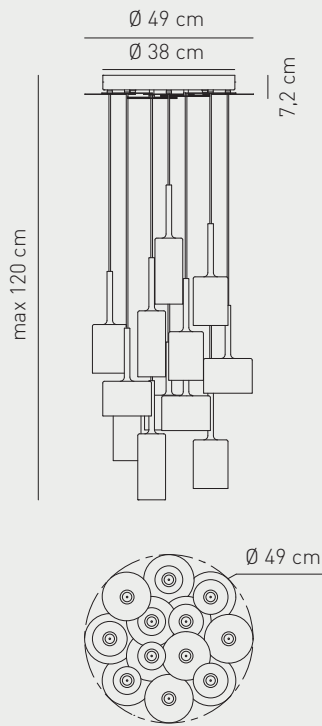

SP SPIL 12

base / bulb type G4 halogen
power 12 x max 20 W
ilcos HSGST/UB 
marks CE  12V IP20



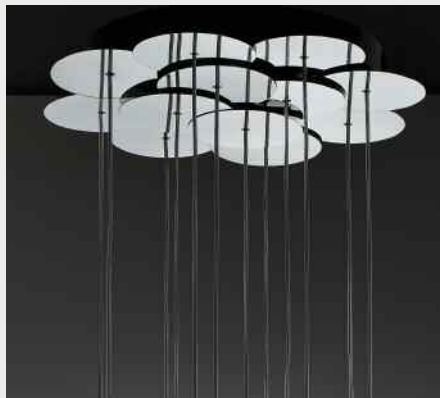
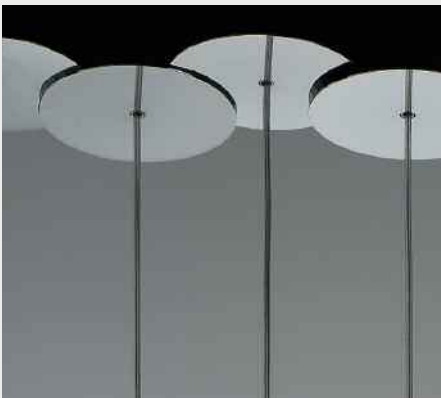
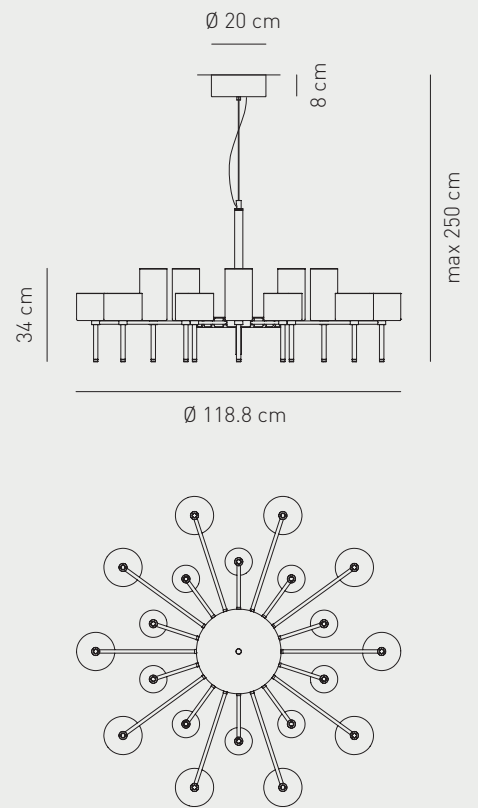

SP SPIL 20

base / bulb type G4 halogen
power 20 x max 10 W
ilcos HSGST/UB 
marks CE  12V IP20



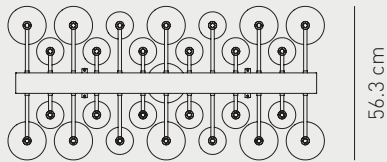
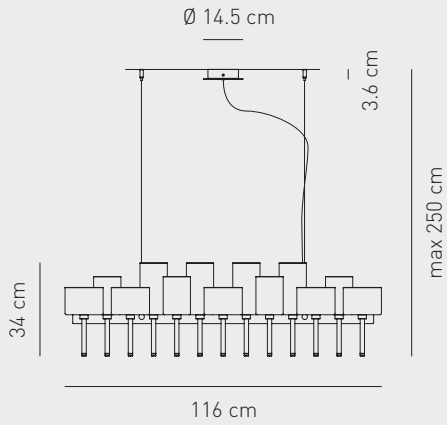

SP SPIL 26

base / bulb type G4 halogen
power 26 x max 10 W
ilcos HSGST/UB 
marks CE   12V IP20



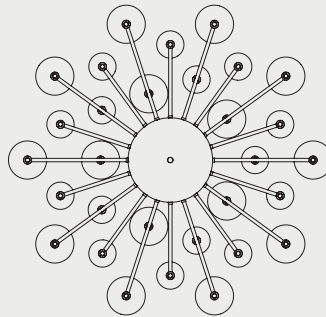
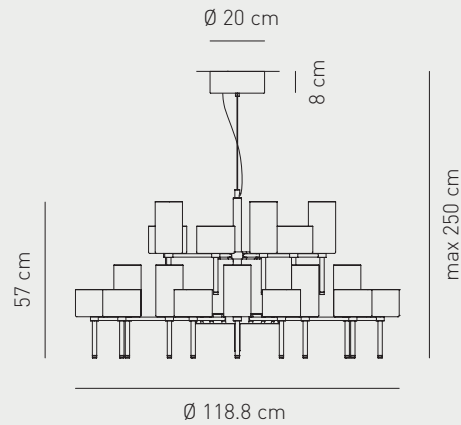

SP SPIL 30

base / bulb type G4 halogen
power 30 x max 10 W
ilcos HSGST/UB 
marks CE   12V IP20



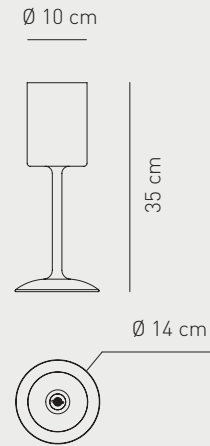

LT SPILL P

base / bulb type G4 halogen
power 1 x max 20 W
ilcos HSGST/UB 
marks CE   12V IP20





LT SPILL G

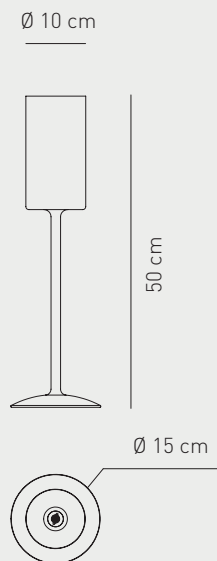

base / bulb type G4 halogen
power 1 x max 20 W
ilcos HSGST/UB 
marks CE   12V IP20



SPIRY WHITE VARNISHED FITTINGS

SP SPIRY



base / bulb type E27 halogen
power 1 x max 100 W
ilcos HSGST/C/UB 
marks CE  IP20

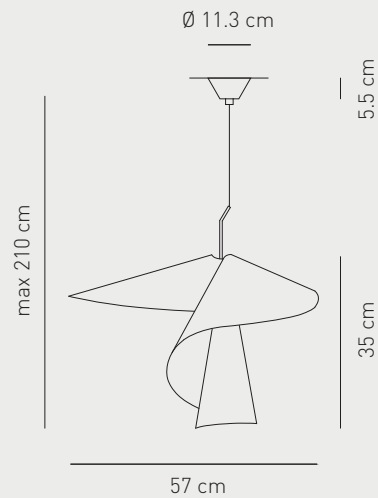

base / bulb type E27 fluorescent
power 1 x max 23 W
ilcos FB 
marks CE  IP20







STORMY WHITE VARNISHED FITTINGS

PL STOR 60

base / bulb type E27 incandescent
power 2 x max 100 W
ilcos IAA/C 
marks CE  IP20

base / bulb type E27 halogen
power 2 x max 70 W
ilcos HSGSA/UB 
marks CE  IP20



base / bulb type E27 fluorescent
power 2 x max 20 W fluo
ilcos FBT 
marks CE  IP20

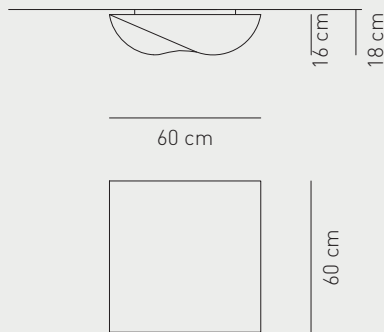

base / bulb type 2GX13 fluorescent
power 1 x 55 W
ilcos FC-55 
marks CE  IP20



application: both as ceiling or wall lamp





PL STO 100

base / bulb type E27 incandescent
power 3 x max 100 W
ilcos IAA/C 
marks CE  IP20

base / bulb type E27 halogen
power 3 x max 70 W
ilcos HSGSA/UB 
marks CE  IP20



base / bulb type E27 fluorescent
power 3 x max 20 W fluo
ilcos FBT 
marks CE  IP20

base / bulb type 2GX13 fluorescent
power 1 x 55 W
ilcos FC-55 
marks CE  IP20

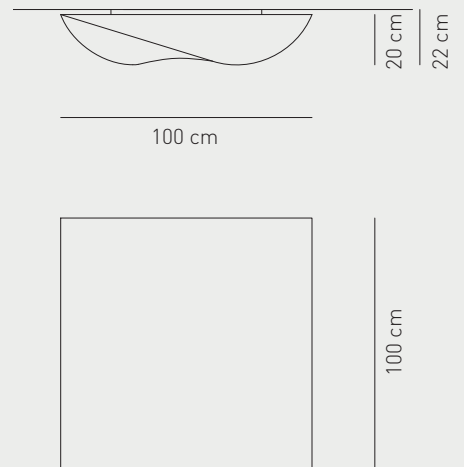
application: both as ceiling or wall lamp





FA SUBZER

base / bulb type G4 halogen
 power 1 x max 20 W
 ilcos HSGST/UB 
 marks CE 12V 

hole Ø 4 cm / min depth 10 cm





FA SUBZ 15

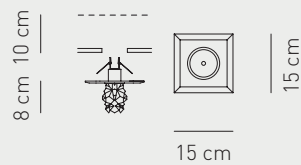

base / bulb type G4 halogen
 power 1 x max 20 W
 ilcos HSGST/UB 
 marks CE 12V 

hole Ø 4 cm / min depth 10 cm





AP SUBZER

base / bulb type E14 incandescent
 power 1 x max 40 W
 ilcos IBB/C 
 marks CE 

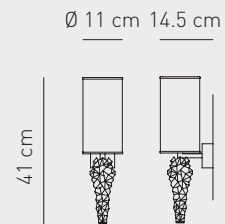
base / bulb type E14 fluorescent
 power 1 x max 9 W fluo
 ilcos FBC 
 marks CE 



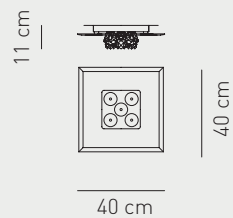

PL SUBZE 5

base / bulb type G4 halogen
 power 5 x max 20 W
 ilcos HSGST/UB 
 marks CE 12V 



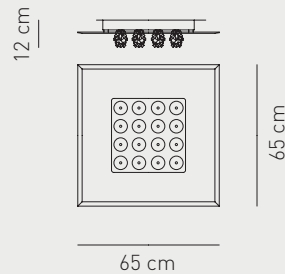

PL SUBZ 16

base / bulb type G4 halogen
 power 16 x max 20 W
 ilcos HSGST/UB 
 marks CE 12V 



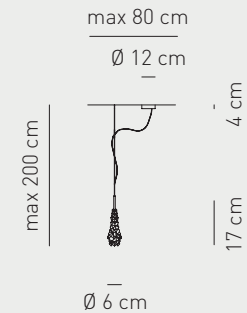

SP SUBZ DE

base / bulb type G4 halogen
 power 1 x max 20 W
 ilcos HSGST/UB 
 marks CE 12V 



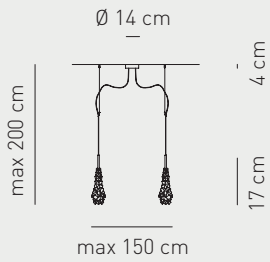

2 X SP SUBZ DE

base / bulb type	G4 halogen
power	2 x max 20 W
ilcos	HSGST/UB 
marks	CE 12V 



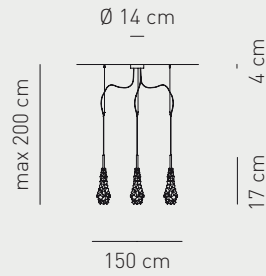

3 X SP SUBZ DE

base / bulb type	G4 halogen
power	3 x max 20 W
ilcos	HSGST/UB 
marks	CE 12V 



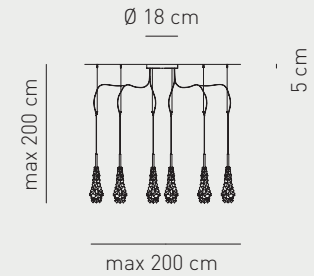

6 X SP SUBZ DE

base / bulb type	G4 halogen
power	6 x max 20 W
ilcos	HSGST/UB 
marks	CE 12V 



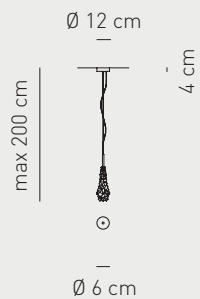

SP SUBZE P

base / bulb type	G4 halogen
power	1 x max 20 W
ilcos	HSGST/UB 
marks	CE 12V 



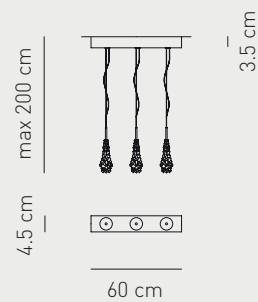

SP SUBZE 3

base / bulb type	G4 halogen
power	3 x max 20 W
ilcos	HSGST/UB 
marks	CE 12V 



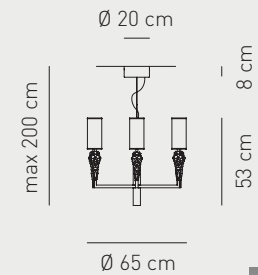

SP SUBZ 06

base / bulb type	E14 incandescent + GU10 halogen
power	6 x max 40 W + 1 x max 50 W alu
ilcos	IBB/C + HRGS/UB 
marks	CE 



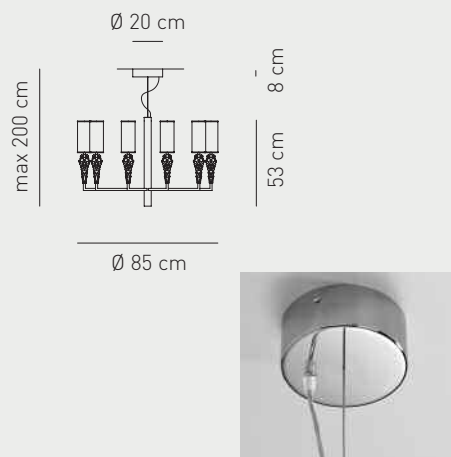

SP SUBZ 10

base / bulb type	E14 incandescent + GU10 halogen
power	10 x max 40 W + 1 x max 50 W alu
ilcos	IBB/C + HRGS/UB 
marks	CE  IP20



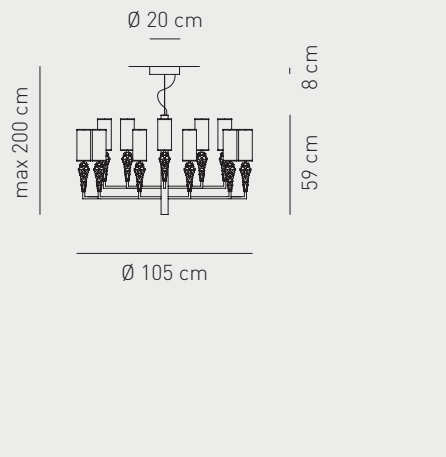

SP SUBZ 20

base / bulb type	E14 incandescent + GU10 halogen
power	20 x max 40 W + 1 x max 50 W alu
ilcos	IBB/C + HRGS/UB 
marks	CE  IP20





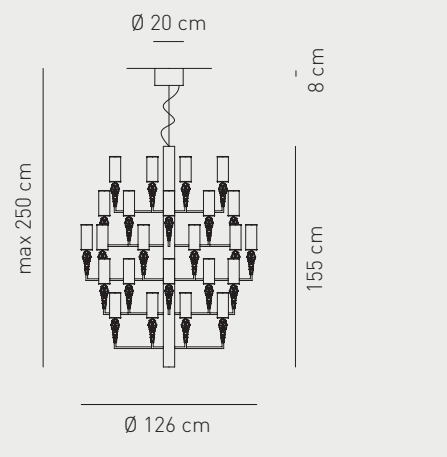

SP SUBZ 50

base / bulb type	E14 incandescent + GU10 halogen
power	50 x max 40 W + 1 x max 50 W alu
ilcos	IBB/C + HRGS/UB 
marks	CE  IP20





LT SUBZER

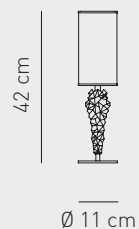

base / bulb type	E14 incandescent
power	1 x max 40 W
ilcos	IBB/C 
marks	CE  IP20

base / bulb type	E14 fluorescent
power	1 x max 9 W fluo
ilcos	FBC 
marks	CE  IP20







SP SUNSH 1

base / bulb type E27 halogen
 power 1 x max 100 W
 ilcos HSGST/UB 
 marks CE  IP20

base / bulb type E27 fluorescent
 power 1 x max 23 W
 ilcos FB-CFL (globe) 
 marks CE  IP20



SP SUN DE 1



base / bulb type E27 halogen
 power 1 x max 100 W
 ilcos HSGST/UB 
 marks CE  IP20

base / bulb type E27 fluorescent
 power 1 x max 23 W
 ilcos FB-CFL (globe) 
 marks CE  IP20

available also for dec. suspensions with 2 or 3 lights / for decentralized suspensions with more than 1 light, please contact Axo Light department



PT SUNSHA

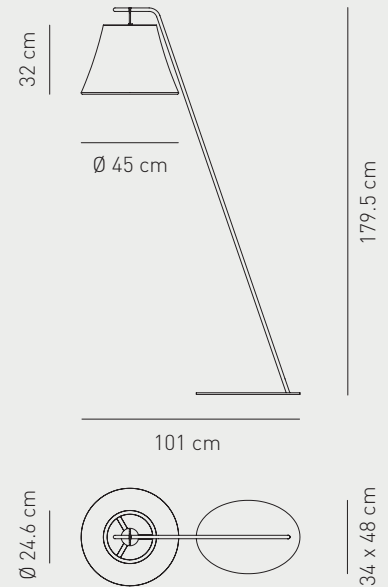
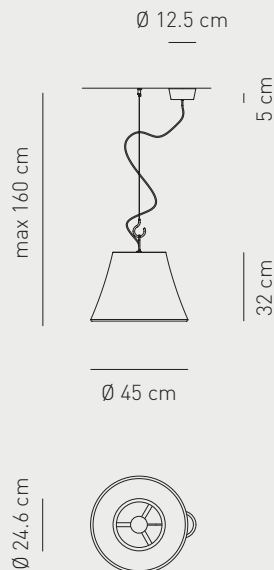
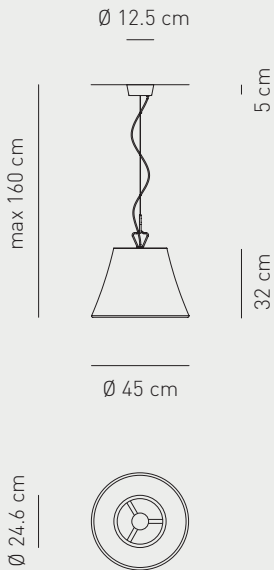

base / bulb type E27 halogen
 power 1 x max 100 W
 ilcos HSGST/UB 
 marks CE  IP20



base / bulb type E27 fluorescent
 power 1 x max 20 W
 ilcos FB-CFL (dim. only) 
 marks CE  IP20





PL UKIYO P

base / bulb type E27 incandescent
 power 3 x max 60 W
 ilcos IAA/C 
 marks  

base / bulb type E27 halogen
 power 3 x max 42 W
 ilcos HSGSA/UB 
 marks  



base / bulb type E27 fluorescent
 power 3 x max 20 W fluo
 ilcos FB-CFL 
 marks  

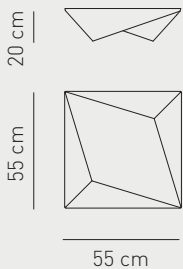

base / bulb type 2GX13 fluorescent
 power 1 x 55 W
 ilcos FC-55 
 marks  



application: both as ceiling or wall lamp





PL UKI 110

base / bulb type E27 incandescent
 power 3 x max 100 W
 ilcos IAA/C 
 marks  

base / bulb type E27 halogen
 power 3 x max 70 W
 ilcos HSGSA/UB 
 marks  



base / bulb type E27 fluorescent
 power 3 x max 20 W fluo
 ilcos FB-CFL 
 marks  

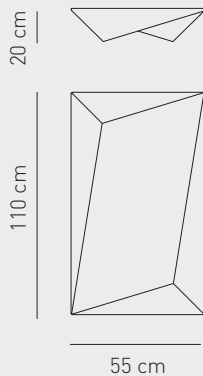

base / bulb type 2GX13 fluorescent
 power 1 x 55 W
 ilcos FC-55 
 marks  



application: both as ceiling or wall lamp





PL UKIYO G

base / bulb type E27 incandescent
 power 3 x max 100 W
 ilcos IAA/C 
 marks  



base / bulb type E27 halogen
 power 5 x max 70 W
 ilcos HSGSA/UB 
 marks  

base / bulb type E27 fluorescent
 power 3 x max 20 W fluo
 ilcos FB-CFL 
 marks  

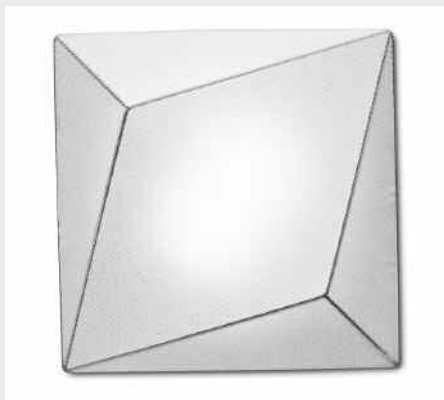
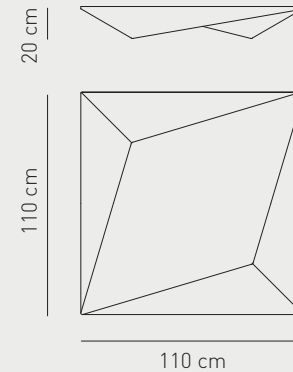
base / bulb type 2GX13 fluorescent
 power 1 x 55 W
 ilcos FC-55 
 marks  



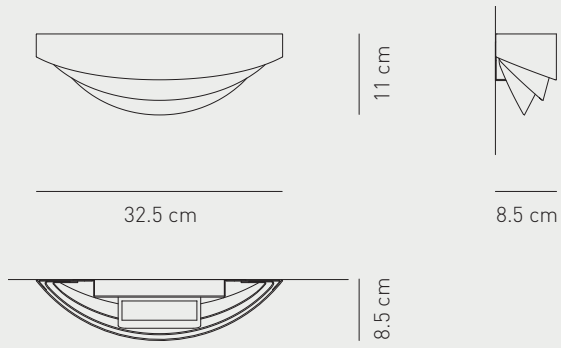

AP URIEL P

base / bulb type R7s halogen eco
power 1 x max 120 W (78)
ilcos HDG 
marks   IP20



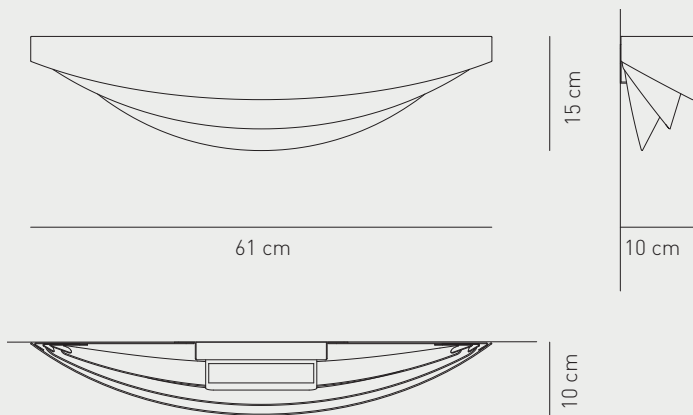

AP URIEL G

base / bulb type R7s halogen eco
power 1 x max 160 W (118)
ilcos HDG 
marks   IP20



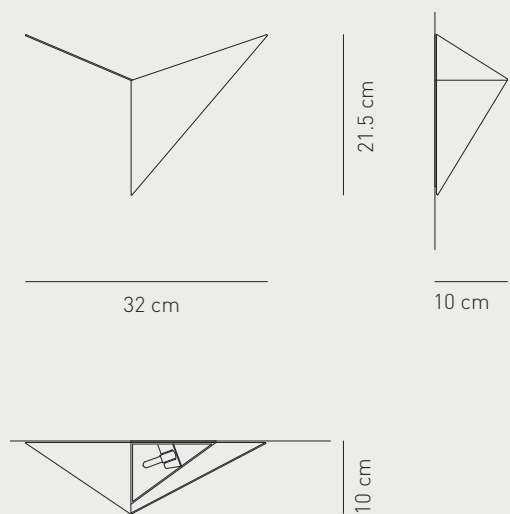

AP VASILY

base / bulb type G9 halogen
power 1 x max 60 W
ilcos HSGST/C/UB 
marks CE  IP20



AP VASILY WITH OPTIONAL BACKPLATE

base / bulb type G9 halogen
power 1 x max 60 W
ilcos HSGST/C/UB 
marks CE  IP20

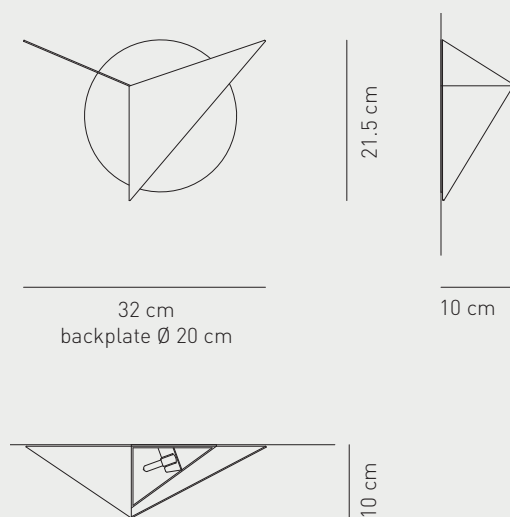

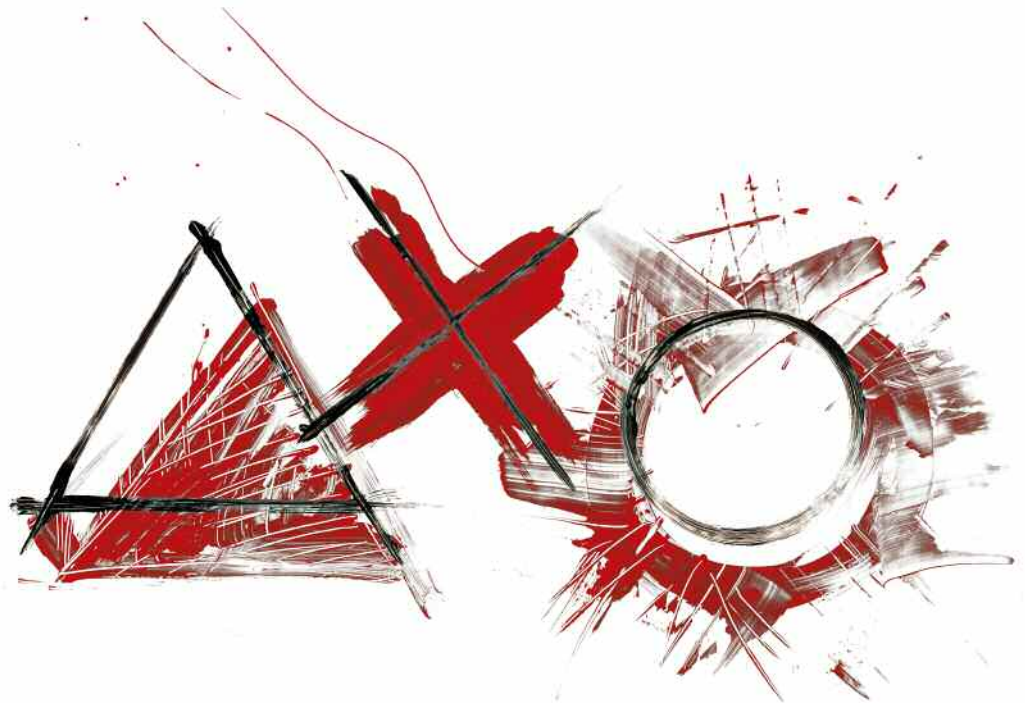

AXO LIGHT SRL

via Moglianese 44
30037 Scorzè
Venezia, Italy
t +39 041 5845193
f +39 041 5845060

AXO LIGHT USA INC.

22 Shelter Rock Lane STE# 104
Danbury, CT, 06810 USA
t +1 (203) 730 0452
f +1 (203) 730 0460
info@axolightusa.com
www.axolightusa.com

AXO LIGHT ASIA LIMITED

RM305-306, Office Building
No.2 Tiantaiyi Road
Science Town, Luogang District
510670 Guangzhou - PRC
t +86 20 38316571
f +86 20 38251165

axolight@axolight.it
www.axolight.it

